



KOD(E)/ECoS/002/2024

SABAH DISTRIBUTION CODE



SABAH DISTRIBUTION CODE

[KOD(E)/ECoS/002/2024]

IN exercise of the power conferred by Section 99 of the Electricity Supply Enactment 2024, the Energy Commission of Sabah (Commission) with the approval of the Minister issues the Sabah Distribution Code:

Purposes

1. The issuance of Sabah Distribution Code is necessary for the following purposes:
 - i) to incorporate the requirement of Sabah's distribution system into the Code; and
 - ii) to facilitate and determine the requirements for connecting large scale solar photovoltaic plants and other distributed generation into the system.

Interpretation

2. In this Code the term and expression used shall, unless defined in the Distribution Code or the context otherwise requires, have the same meaning as in the Enactment or regulation made under it.

Citation and Commencement

3. This Code may be cited as the Sabah Distribution Code and shall be as in **ANNEX I**.
 4. This Code was approved by the Minister on 19 December 2023 and was issued by the Commission on 29 December 2023, and shall come into force on the date of its issuance.
-

Application of the Code

5. This Code shall apply to the parties connected to the Distribution System, i.e., Large Power Consumers, Embedded Distributors, Distributed Generators and any person who is licensed under Section 8 of the Electricity Supply Enactment and connected to the electricity distribution network or any person connected to, or intends to connect to, the electricity distribution network located in Sabah.

Notice by the Commission

6. Commission may issue written notices from time to time in relation to the Code.

Amendment and Variation

7. Commission may at any time amend, modify, vary or revoke this Code or any part thereof, under the following circumstances:
 - i) to effect changes in the electricity supply industry;
 - ii) where it is expedient to ensure reliability of the electricity supply system;
 - iii) to rectify any inconsistency or unintentional errors giving rise to grave consequences;
 - iv) as recommended by the Distribution Code Committee and approved by the Commission;
 - v) any other justifiable reason as Commission deems necessary.

Dated: 3rd January 2024



DATUK Ir. ABDUL NASSER BIN ABDUL WAHID

Chief Executive Officer
Energy Commission of Sabah

ANNEX I:

SABAH DISTRIBUTION CODE



DOCUMENT CONTROL

Version #	Revised by	Revision date

Contents

PREFACE	12
1.1 INTRODUCTION.....	12
1.2 ELECTRICITY SUPPLY INDUSTRY IN SABAH.....	12
1.3 ELECTRICITY DISTRIBUTION FUNCTIONS, LICENCE STANDARDS AND THE DISTRIBUTION CODE.....	13
1.4 REGULATORY ARRANGEMENTS.....	14
1.5 CONTENTS OF THE DISTRIBUTION CODE.....	15
DISTRIBUTION GLOSSARY AND DEFINITIONS	16
2.1 EXPRESSIONS.....	16
INTRODUCTION	30
3.1 OBJECTIVES.....	30
3.2 SCOPE.....	30
3.3 PURPOSE OF DISTRIBUTION CODE.....	30
3.4 GOVERNANCE ARRANGEMENTS.....	31
3.4.1 Establishment of the Distribution Code.....	31
3.4.2 Legacy arrangements, Derogations and Exemptions.....	33
3.4.3 Disputes.....	33
3.5 DESCRIPTION OF THE CONTENTS OF THE DISTRIBUTION CODE.....	34
3.5.1 Sections of the Distribution Code.....	34
3.5.2 Annexes of the Distribution Code.....	36
DISTRIBUTION GENERAL CONDITIONS	37
4.1 INTRODUCTION.....	37
4.2 SCOPE.....	37
4.3 OBJECTIVES.....	37
4.4 INTERPRETATION.....	37
4.5 DISTRIBUTION CODE COMMITTEE (DCC).....	38
4.6 UNFORESEEN CIRCUMSTANCES.....	40
4.7 EMERGENCY SITUATIONS.....	40
4.8 NON-DISCRIMINATION.....	40
4.9 LEGACY ARRANGEMENTS AND DEROGATIONS.....	41
4.10 CONFIDENTIALITY.....	43
4.11 NOTICES AND COMMUNICATION.....	44
DISTRIBUTION PLANNING CODE	45
5.1 INTRODUCTION.....	45
5.2 SCOPE.....	45
5.3 OBJECTIVES.....	46

5.4	PLANNING AND DESIGN CRITERIA	46
5.4.1.	General	46
5.4.2.	Security Standards	47
5.4.3.	System Frequency.....	49
5.4.4.	Steady-State Supply Voltage Variation	49
5.4.4.1	Steady-state Voltage Variation under Normal conditions	49
5.4.4.2	Steady-state Voltage Variation under Contingency Condition.....	49
5.4.4.3	Steady-State Voltage Variation at the Interfaces with Transmission Bulk Supply Substation.....	50
5.4.5.	Short Duration Supply Voltage Variation.....	50
5.4.6.	Power Quality and Disturbing Loads.....	51
5.4.7.	Superimposed Signals	54
5.4.8.	Transient Over voltages	55
5.4.9.	Short Circuit Levels	55
5.5	TECHNICAL STANDARDS AND SPECIFICATION OF EQUIPMENT.....	56
5.6	EARTHING.....	56
5.7	PROTECTION AND CONTROL	57
5.7.1	General.....	57
5.7.2	Specific Protection Requirements	57
5.8	DISTRIBUTED GENERATION PLANNING AND DESIGN	58
5.9	DISTRIBUTION SYSTEM PLANNING.....	59
5.10	DEMAND FORECASTS.....	60
5.10.1	General.....	60
5.10.2	Consumers Demand Forecast	62
5.10.3	Embedded Distributors Demand Forecast.....	62
5.10.4	Distributed Generators Generating Plant Output Forecast.....	63
5.10.5	Factors to be considered for Demand Forecasts.....	63
5.11	INFORMATION TO USERS.....	63
5.11.1	Load Profiles and Characteristics at Connection Points.....	63
5.11.2	Load Profiles.....	64
5.11.3	Power Quality Characteristics	64
	DISTRIBUTION OPERATING CODE	65
6.1	INTRODUCTION.....	65
6.2	SCOPE.....	65
6.3	OBJECTIVES	66
6.4	DISTRIBUTION OPERATIONAL PLANNING.....	66
6.4.1	Annual Operation Plan	66
6.4.2	Operational Demand and Generation Forecasts	67
6.4.2.1	General	67
6.4.2.2	Major Changes in Consumer's Demand Forecast.....	68
6.4.2.3	Major Changes in Embedded Distributor Demand Forecast.....	68

6.4.2.4	Major Changes in Distributed Generators Generation Output Forecast	68
6.4.3	Annual Operating Data	69
6.4.3.1	General	69
6.4.3.2	Consumer's Operating Data	69
6.4.3.3	Embedded Distributor's Operating Data	70
6.4.3.4	Distributed Generator's Operating Data	70
6.5	OPERATION CRITERIA	71
6.5.0	General	71
6.5.1	Security of Supply	71
6.5.2	Circuit Loading	72
6.5.3	Steady State Voltage Variations	72
6.5.4	Short Duration Voltage Variations	73
6.5.5	Requirements for Network Support from DG (Solar PV Type)	74
6.5.5.1	Low Voltage Ride Through	74
6.5.5.2	Frequency disturbance	75
6.5.5.3	Power output management	75
6.5.5.4	Droop curve	75
6.5.5.5	Reactive power	76
6.6	MONITORING AND TESTING OF PERFORMANCE	76
6.6.1	General	76
6.6.2	Steady-state Voltage Limits	76
6.6.3	Power Quality Related Monitoring	77
6.6.4	Obligations of Users to Monitor and/or Test Performance	78
6.7	SAFETY REQUIREMENTS	78
6.7.0	General	78
6.7.1	Operational Responsibilities	79
6.7.2	Safety Coordination	79
6.7.3	Competency of Persons	80
6.7.4	Reporting of Accidents	80
6.8	OPERATIONAL REQUIREMENTS	81
6.8.1	Distribution System Control Structure	81
6.8.2	Operational Liaison Arrangements	82
6.8.2.1	General	82
6.8.2.2	Notification of Operations	82
6.8.2.3	Notification of Events	83
6.8.2.4	Reporting of Significant Incidents by Users	84
6.8.3	Notification of Scheduled Outages and Interruptions	85
6.8.4	Restoration of Supply	86
6.8.5	Recording System Outages and Interruptions	86
6.9	DEMAND CONTROL AND EMERGENCY OPERATIONS	87
6.9.1	General	87
6.9.2	Responsibilities of the Distributor and Users	88
6.9.3	Automatic Low Frequency Load Disconnection	89
6.9.4	Automatic Low Voltage Load Disconnection	89

6.9.5	Manual Disconnection of Users.....	89
6.9.6	Rota Demand Control to Manage Longer Term Emergencies	90
6.9.7	Black Start	90
	6.9.7.1 General	90
	6.9.7.2 Black Start Distributed Generating Units	90
6.10	MAINTENANCE COORDINATION REQUIREMENTS	91
	6.10.1 General	91
	6.10.2 Maintaining Records on Distribution System User Equipment	91
	6.10.3 Maintenance Coordination of Equipment at the Point of Interfaces	92
	6.10.4 Protection Equipment and Revenue Metering Equipment Maintenance	92
	6.10.5 Protection Equipment Coordination	93
DISTRIBUTION CONNECTION CODE.....		95
7.1	INTRODUCTION.....	95
7.2	SCOPE.....	95
7.3	OBJECTIVES	95
7.4	GENERAL REQUIREMENTS FOR CONNECTION	96
	7.4.1 Provision of an Electricity Supply to Users	96
	7.4.2 Security and Quality of Supply	96
	7.4.3 Inspection of User Installations by the Distributor.....	97
	7.4.4 Connection Point and Ownership Boundaries	97
	7.4.4.1 Connection Point	97
	7.4.4.2 Plant or Apparatus Ownership.....	98
	7.4.5 User to Furnish Right Of Way	98
	7.4.6 Service to Contiguous Property.....	98
	7.4.7 User to Protect Distributors Property	99
	7.4.8 Exchange of Data between User and Distributor.....	99
	7.4.9 Power Quality Disturbances.....	99
	7.4.10 Limitation of Use by the User	100
	7.4.11 Design Principles	100
7.5	CONNECTION REQUIREMENTS FOR CONSUMERS CONNECTED AT LV.....	101
	7.5.1 Declaration of Load and its Characteristics	101
	7.5.2 Technical Requirements for Connection.....	102
7.6	CONNECTION REQUIREMENTS FOR CONSUMERS CONNECTED AT MV.....	102
	7.6.1 Declaration of Load and its Characteristics	102
	7.6.2 Technical Requirements for Connection.....	104
7.7	CONNECTION REQUIREMENTS FOR EMBEDDED DISTRIBUTORS.....	106
	7.7.1 General	106
	7.7.2 Information to be Provided to the Distributor	106
	7.7.3 Technical Requirements for Connection	107
7.8	CONNECTION REQUIREMENTS FOR DISTRIBUTED GENERATORS.....	109
	7.8.1 General	109
	7.8.2 Information to be Provided to the Distributor	110
	7.8.3 Technical Requirements for Connection.....	114
	7.8.4 Standby and Top Up Supply	118

DISTRIBUTION DATA REGISTRATION CODE.....	119
8.1 INTRODUCTION.....	119
8.2 SCOPE.....	119
8.3 OBJECTIVES.....	119
8.4 PROCEDURES AND RESPONSIBILITIES.....	120
8.4.1 Responsibility for Submission and Updating of Data.....	120
8.4.2 Methods of Submitting Data.....	120
8.4.3 Changes to User's Data.....	120
8.4.4 Data Accuracy.....	120
8.4.5 Estimated Data.....	121
8.5 DATA TO BE REGISTERED.....	121
8.5.0 General.....	121
8.5.1 System Planning Demand Forecasts – Schedule 5.....	121
8.5.2 Operational Demand Forecast Data – Schedule 6.....	122
8.5.3 Load Characteristics and Connection Data.....	122
8.5.4 Data Schedules.....	122
Schedule 5 – Form 5A: Distributors Load Forecast to the Grid System Operator.....	125
Schedule 5 – Form 5B: Consumer Load Forecast to the Distributor.....	126
Schedule 5 – Form 5C: Embedded Distributor Load Forecast to the Distributor.....	128
Schedule 5 – Form 5D: Distributed Generator Plant with output of 1 MW or more – Load Forecast to the Distributor.....	134
Schedule 5 – Form 5E: Load profiles at the point of interfaces.....	137
Schedule 5 – Form 5F: Power Quality Records.....	141
Schedule 6 – Form 6B: Consumer Load Forecast Changes to the Distributor.....	145
Schedule 6 – Form 6C: Changes Embedded Distributor Load Forecast to the Distributor.....	148
Schedule 6 – Form 6D: Distributed Generator Load Forecast Changes.....	151
METERING CODE.....	154
9.1 INTRODUCTION.....	154
9.2 OBJECTIVES.....	154
9.3 SCOPE.....	154
9.4 GENERAL REQUIREMENTS.....	155
9.4.1 Legal Requirements.....	155
9.4.2 Location of Revenue Metering Equipment.....	155
9.4.3 Access and Security of Revenue Metering Equipment.....	156
9.4.4 Provision of Metering Signals.....	156
9.4.5 Transformer Operated Metering.....	157
9.4.6 Main and Check Metering.....	157
9.4.7 Summation Metering.....	158
9.5 SPECIFICATION AND ACCURACY OF REVENUE METERING.....	158
9.5.1 General.....	158
9.5.2 Revenue Metering Equipment Specifications.....	159
9.5.3 Type and Accuracy of Revenue Metering Equipment.....	159
9.5.3.1 General.....	159

9.5.3.2 Single Phase Whole Current Metering	159
9.5.3.3 Three Phase Whole Current Metering	160
9.5.3.4 Three Phase Transformer Operated Metering.....	160
9.6 TESTING REQUIREMENTS.....	161
9.6.1 Test and Certification Procedures	161
9.6.2 On-site Testing of Revenue Metering Equipment	162
9.7 CONFIDENTIALITY	163
9.8 DISPUTES.....	163
SPECIFIC REQUIREMENT	164
10.1 OBJECTIVES	164
10.2 SCOPE	164
10.3 RURAL DISTRIBUTION SYSTEM.....	164
10.3.0 General.....	164
10.3.1 Security level	164
10.3.2 Exception	165
10.4 DISTRIBUTED GENERATION	165
10.4.0 General.....	165
10.4.1 Boundary of Responsibilities	165
10.4.2 Distributed Generation Planning and Design	166
10.4.3 Power System Study.....	166
10.5 FORMATION OF ISLANDED GRID	167
10.5.1 General	167
10.5.2 Operation during islanded mode	167
10.5.3 Requirements for Black start	168
10.5.4 Operation Criteria of Islanded Grid	168
10.5.5 Automatic Low Frequency Load Disconnection	168
10.5.6 Automatic Low Voltage Load Disconnection.....	168
10.6 CONDITION TO ACCEPT	169
10.6.0 General	169
ANNEXES	170
ANNEX 1: DISTRIBUTOR'S LICENCE OBLIGATIONS	171
ANNEX 2: STANDARDS REFERENCED IN THE DISTRIBUTION CODE.....	172
ANNEX 3: RULES OF THE DISTRIBUTION CODE COMMITTEE	174

Preface

1.1 Introduction

1.1.1 This preface is provided to **Users** and to prospective **Users** of the **Distribution System** for information only and it does not constitute part of the **Distribution Code**.

1.1.2 The purpose of the preface is to provide brief background information on the **Electricity Supply Industry** in Sabah the electricity **Distribution** functions, the requirements for **Licence Standards**, the need for the **Distribution Code** and a summary of the contents of the **Distribution Code**.

1.2 Electricity Supply Industry background in Sabah

1.2.1 The **Transmission System** consists of that part of the system that operates at 66kV and above and is owned and operated by **SESB**. A part of **SESB Transmission Division** carries out the functions of Transmission System asset owner, operator and maintainer while another part assumes the function of the **Grid System Operator (GSO)** who is responsible for coordinating the operation of the **Grid System** and for the least-cost scheduling and dispatch of generation. Another important part of **SESB Transmission Division** is the **Single Buyer** who is responsible for contracts, purchase and settlement of energy and power in the wholesale generation market.

1.2.2 The **Distribution System** is that part of the system that operates below 66 kV (33kV, 11kV, 230Volt, and 400Volt). Notwithstanding other Distributor which may incorporate in the Distribution system operating at 132kV and below. Responsibility for electricity **Distribution** includes purchase of power from the **Grid System** at **Transmission Main Intake Substations**, provision and operation of **Distribution Network** at both **Medium** and **Low Voltages** and provision of service lines for retail sales of electricity to **Consumers**.

1.2.3

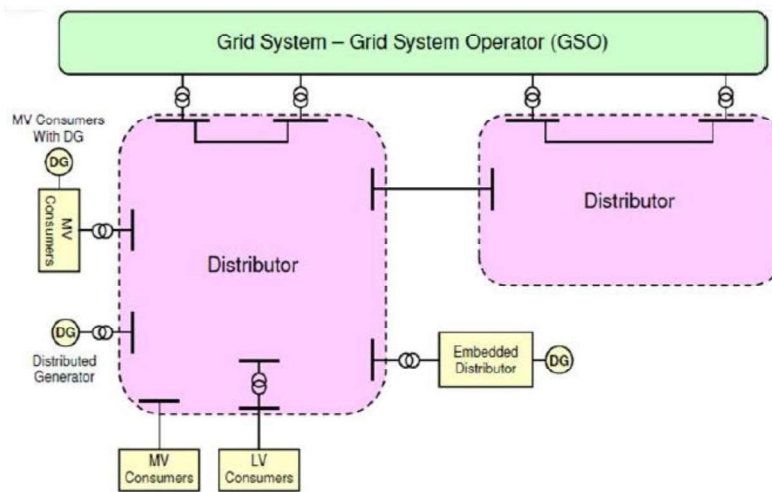

1.3 Electricity Distribution Functions, Licence Standards and the Distribution Code

1.3.1 In ensuring acceptable **Security of Supply** and satisfactory degree of **Power Quality** delivered to the **Consumers**, the **Distribution Function** of an **Electric Power System** must be carried out with the following two main objectives to satisfy the requirements of the Electricity Supply Enactment 2024 and Electricity Supply Regulations 2024 and other laws, and the terms and conditions of the Licences:

- a) Developing and maintaining an efficient and safe **Distribution System** for supply of electrical energy to **Consumers**; and
- b) Ensuring availability of electrical energy supply and power quality at appropriate levels for all **Consumers**.

1.3.2 The electric power **Distribution System** needs to be planned, designed, operated and maintained in accordance to certain **Standards** as required by the Licence Conditions and these Standards are termed as the **Licence Standards**. **Licence Standards** contain criteria, procedures, requirements and limits for the planning, design, operation and maintenance of the **Distribution System**. These **Standards** are established by the **Distributor** with the concurrence of Commission.

- 1.3.3 Since the **Distribution System** is also being used by other parties such as **Distributed Generators, Embedded Distributors** and **Large Power Consumers** who are collectively known as **Users**, and to enable and ensure that the **Distributor** is able to meet its **Licence** obligations, it is necessary for these **Users** to comply to certain rules and procedures (particularly at the interface between the **Distribution System** and the **User's System**), that prior to the establishment of this **Distribution Code** are contained in the appropriate agreements between each **User** and the **Distributor**.
- 1.3.4 The **Distribution Code** is a document containing a set of technical rules and Procedures that facilitate coordinated planning, coordinated design, coordinated development, and coordinated operation and safety of the **Distribution System**.
- 1.3.5 Coordination listed in 1.3.4 is carried out by the **Distributor** with the **Users** of the **Distribution System**. The **Distribution Code** also enables the **Distributor** to comply with the **Grid Code**. In addition, the **Distribution Code** provides a defined normal level of **Security of Supply** and **Power Quality** for power delivered to **Consumers**.
- 1.4 Regulatory Arrangements**
- 1.4.1 The electricity industry in Malaysia is regulated through the Electricity Supply Enactment 2024 and the subsidiary legislation made thereunder, namely the Electricity Supply Regulations 2024 and the Licencee Supply Regulations 2024.
- 1.4.2 The Energy Commission of Sabah Enactment 2023 established the **Commission** of Sabah with powers to regulate the electricity supply industry and activities in Malaysia, and to enforce the electricity supply laws, and for matters connected therewith.
- 1.4.3 The main functions and duties of the **Commission** set out in the Electricity Supply Enactment 2024 includes the following:
- i) to issue **Licences** for generation, transmission and/or distribution of electricity;

- ii) to exercise regulatory functions relating to the service and performance of the **Licencees**;
- iii) to promote competition in the generation and supply of electricity; and
- iv) to promote the interests of the customers (**Consumers**) as to the prices charged, the continuity and quality of supply.

1.4.4 The **Grid System Operator (GSO)** is required to maintain and implement a **Grid Code** which specifies the technical arrangements for operating the **Grid System** and for the least-cost scheduling and dispatch of generation. **Users** of the **Grid System** and the **GSO** are required to comply with the provisions of the **Grid Code** as provided for in each **User's Licence Conditions**.

1.4.5 **Distributors** are required jointly to establish and maintain a **Distribution Code** covering the technical requirements relating to the connection to and use of the **Distribution System**. **Users** of the **Distribution System** and the **Distributors** are required to comply with the provisions of the **Distribution Code** as provided for in each **User's Licence Conditions**.

1.5 Contents of the Distribution Code

1.5.1 The **Distribution Code** comprises the following sections:

- (1) Introduction;
- (2) General Conditions;
- (3) Distribution Planning Code;
- (4) Distribution Operating Code;
- (5) Distribution Connection Code;
- (6) Distribution Data Registration Code;
- (7) Distribution Metering Code; and
- (8) Specific Requirement for Sabah.

1.5.2 Each section of the **Distribution Code** addresses a specific subject area associated with an activity related to ensuring efficient and safe **Distribution System** for the benefit of all connected **Consumers** and **Users**. Each section also defines the duties and responsibilities of the **Distributor** and the **Users** towards compliance with the **Distribution Code**.

Distribution Glossary and Definitions

2.1 Expressions

2.1.1 In this **Distribution Code** the following words and expressions, printed in bold capitalized text throughout the **Distribution Code**, shall, unless the subject matter or context otherwise requires or is inconsistent therewith, bear the listed meaning:

Term	Definition
Active Energy	The electrical energy produced, flowing or supplied by an electric circuit during a time interval, being the integral with respect to time of the instantaneous Active Power and normally measured in kWh or MWh.
Active Power	The multiple of the components of alternating current and voltage that equate to true power, normally measured in kilowatts (kW) or megawatts (MW).
Agreement	Any technical and/or commercial agreement signed between two or more parties in the Malaysian Electricity Supply Industry.
Annual Operation Plan	The plan required to be prepared by Distributors in accordance with Section 6.4.1 of the DOC setting out the strategy for operation of the Distribution System for the relevant period. This includes the Operating Plan required to be prepared by Embedded Distributors in accordance with Section 6.4.3.3 of the DOC and to be submitted to the Distributor.
Apparent Power	Product of voltage and alternating current measured in kVA or MVA
Apparatus	Any electrical apparatus and includes the device or fitting in which a conductor is used, or of which it forms part of.
Area of Supply	The geographical area specified in the Licence which defines the limits of the Distributor's Distribution System/ Embedded Distributor's Distribution System .
Authorised Personnel	A person who is formally empowered to perform specified duties associated with an office or an agreement or contract.

Term	Definition
Black Start	The procedure necessary for a recovery from a Total Blackout or Partial Blackout .
Distributed Generating Unit	A Generating Unit connected to the Distribution System identified as being capable of starting up, from shut down without the need for external power supply connections.
CAIDI	Customer Average Interruption Duration Index for sustained interruptions. This distribution reliability index represents the average time required to restore service to the average customer per sustained interruption.
CAIDI	Customer Average Interruption Duration Index for sustained interruptions. This distribution reliability index represents the average time required to restore service to the average customer per sustained interruption.
Central Dispatched	The process of scheduling and issuing direct dispatch instructions to Generating Plant by the Grid System Operator pursuant to the Grid Code .
Central Dispatched Generating Unit (CDGU)	Means a Generating Unit with a rated output of 5 MW or more which is subject to dispatch by the Grid System Operator .
Code	In general, a set of rules defining appropriate action, conduct and behaviour and in particular any one of the Chapters or Sections or clauses of this Distribution Code mentioned in context.
Commission	The Commission established under the Commission of Sabah Enactment 2023.
Committee	The Distribution Code Committee .
Communication Protocol	A protocol or procedure established to facilitate the exchange of relevant Data in a timely and orderly manner.
Competent Person	A person, who holds a certificate of competency issued by the Commission to perform work in accordance with the restrictions, if any, stated in the certificate.

Term	Definition
Consumer	A person who is supplied with electricity or whose premises are for the time being connected for the purpose of supply of electricity by a supply authority or Licencee .
Connection Agreement	An agreement between the Distributor/Embedded Distributor and any other entity (owner of Transmission System/Users) setting out the terms relating to a connection with the relevant Distribution System .
Connection Point	Point of entry or exit of the Distribution System
Consumer With Own Generation	A Consumer with one or more Generating Unit(s) connected to the Consumer's System , with or without energy storage system, providing all or part of the Consumer's electricity requirements, and which may use the Distributor's Distribution System or Distribution System of an Embedded Distributor for the transport of any surplus of electricity being exported.
Control Centre	A central location for the control and operation of all, or of part of a Distribution System , a Transmission System or the System of a User which operates at Medium Voltage or higher.
Customer Management Centre	A central location offering an enquiry service for Users and for reporting loss of supply and other incidents on the Distribution System .
Danger	Danger to health or to human life or limb from shock, burn, or other injury and includes danger to property, installation or equipment resulting from the generation, transmission, distribution or utilization of electricity.
Data	Any piece of information, parameter or sets of parameters in pursuance of enabling compliance with this Distribution Code .
Demand	The demand of MW or MVA _r of electricity (i.e., both Active Power and Reactive Power respectively) unless otherwise stated.

Term	Definition
Distributed Generator	A Generator , including a Consumer with Own Generation , whose Generating Units are directly connected to the Distributor's Distribution System or to the Distribution System of an Embedded Distributor which is connected to the Distributor's Distribution System , and not having any connection with the Transmission System .
Distributed Generating Units	Generating Units directly connected to the Distributor's Distribution System or to the Distribution System of an Embedded Distributor which is connected to the Distributor's Distribution System , and not having any connection with the Transmission System
Distribution Code	A code required to be prepared jointly by Distributors in Sabah and approved by the Commission as revised from time to time with the approval of, or by the direction of, the Commission . It sets out the principles governing the relationship between the GSO, EC, Customers and all Users of the Distribution System .
Distribution Code Committee	The standing body established under the Distribution General Conditions (DGC) , also called the Committee .
Distribution Data Registration Code (DDRC)	That portion of the Distribution Code which is identified as the Distribution Data Registration Code .
Distribution General Conditions (DGC)	That portion of the Distribution Code which is identified as the Distribution General Conditions .
Distribution Glossary and Definitions (DGD)	That portion of the Distribution Code which is identified as the Distribution Glossary and Definitions .
Distribution Connection Code (DCC)	That portion of the Distribution Code which is identified as the Distribution Connection Code .

Term	Definition
Distribution Metering Code (DMC)	That portion of the Distribution Code which is identified as the Distribution Metering Code .
Distribution Planning Code (DPC)	That portion of the Distribution Code which is identified as the Distribution Planning Code .
Distribution Operating Code (DOC)	That portion of the Distribution Code which is identified as the Distribution Operating Code .
Distribution System	The system of electric lines with voltage levels below 66 kV, within the Area of Supply owned or operated by the Distributor/Embedded Distributor , for distribution of electricity from Grid Supply Points or Generating Units or other entry points to the point of delivery to Customers or other Distributors and includes any electrical plant and meters owned or operated by the Distributor/ Embedded Distributor in connection with the distribution of electricity.
Distribution System Master Plan	The expansion plan prepared by Distributors in accordance with provision 5.9.1 of the DPC .
Distribution System Planning Review	The annual review of the Distribution System Master Plan prepared by Distributors in accordance with 5.9.1 of the DPC .
Distribution System Recovery Plan	The plan the Distributor is required to prepare under the provisions of 6.9.7.2 of the DOC in order to restore supplies in emergency conditions considered in section 6.9 of the DOC .

Term	Definition
Distributor	A person who is licenced under Section 8 of the Enactment and is connected to the Grid System and distributes electricity for the purpose of enabling a supply to be given to any premises. "Distribute" means to operate, maintain and distribute electricity through the electricity distribution network.
Earthing	A way of providing a connection between conductors and earth by an Earthing Device which is either: <ul style="list-style-type: none"> (a) immobilised and Locked in the Earthing position. Where the Earthing Device is Locked with a Safety Key, the Safety Key must be secured in a Key Safe and the Key Safe Key must be retained in safe custody; or (b) maintained and/or secured in position by such other method which must be in accordance with the Local Safety Instructions of Distributor / Embedded Distributor / User, as the case may be.
Earthing Device	An approved device used for the earthing of Isolated conductors and/or electrical Apparatus .
Electricity Supply Laws	The Electricity Supply Enactment 2024 and <ul style="list-style-type: none"> a) any subsidiary legislation made under the Electricity Supply Enactment 2024; and b) any other legislation relating to electricity under which the Commission is to exercise any function including any subsidiary legislation made under such legislation.
Electromagnetic Environment	IEC/TR 61000-1-1, Electromagnetic compatibility (EMC) <ul style="list-style-type: none"> - Part 1: General-Section 1: Application and interpretation of fundamental definitions and terms, Electromagnetic environment (EM) describes the general voltage characteristics of the electrical power supply systems which comprises of voltage magnitude variations, rapid voltage changes, supply voltage sags, short interruptions of supply voltage, transients, supply voltage unbalance, harmonic voltage etc.

Term	Definition
Electromagnetic Compatibility	IEC/TR 61000-1-1, Electromagnetic compatibility (EMC) - Part 1: General-Section 1: Application and interpretation of fundamental definitions and terms, Electromagnetic Compatibility itself is defined as: "the ability of an equipment or system to function satisfactorily in its electromagnetic environment without introducing intolerable electromagnetic disturbances to anything in that environment."
Embedded Distributor	A person who distributes electricity under a Licence issued under the Enactment and whose Distribution System is connected to the Distributor's Distribution System under a Connection Agreement and not having any connection with the Transmission System ; and who is required to comply with the Distribution Code as a User at a Connection Point with the Distributor's Distribution System and also as a Distributor in respect of his own Distribution System .
Emergency Load Curtailment Plan	The plan the Distributor is required to prepare in accordance with provision of 6.9.2 of the DOC in order to satisfy the requirements of the Grid Code .
Enactment	The Electricity Supply Enactment 2024 including any regulations made hereunder and any amendments thereto.
Energy Storage System	Energy storage system is a device that stores energy to perform useful processes at a later time.
Equipment	Includes any item for such purposes as generation, conversion, transmission, distribution or utilization of electrical energy, such as machines, transformers, Apparatus , measuring instruments, protective devices, wiring materials, accessories and appliances.
Event	An unscheduled or unplanned (although it may be anticipated) occurrence on or relating to a System including, without limiting that general description, faults, incidents and breakdowns and adverse weather conditions being experienced.

Extra Low Voltage	A voltage normally not exceeding 50 volts alternating current or 120 volts direct current, whether between conductors or between conductor and earth.
Extra High Voltage	A voltage normally exceeding 230 000 volts.
Force Majeure	Circumstances beyond the control of the Distributor .
Grid Code	Sabah Grid Code is a document that sets out the principles governing the relationship between the GSO, Commission, Grid Owner, Single Buyer and all Users of the Grid System .
Grid System	Transmission System with directly connected Generating Unit and Directly Connected Customers .
Grid System Operator (GSO)	A part of SESB Operation Division which is responsible for, operation planning, operation and control of the Grid System in compliance with the provisions of the Grid Code .
Grid System Recovery Plan	The plan prepared by the Grid System Operator in accordance with relevant provisions of the Grid Code to restore the Grid System in emergency situations.
Generating Unit	Any Apparatus which produces electricity.
Generator	A person who generates electricity under Licence under the Enactment.

Term	Definition
High Voltage	A voltage normally exceeding medium voltage but equal to or not exceeding 230 000 volts.
IEC	International Electrotechnical Commission.
Islanded Grid	A group of interconnected load and distributed generation within clearly defined electrical boundaries that act as a single controllable entity that could be connected to or disconnected from the grid
Islanding	The condition that occurs when parts of the Network including associated Generating Unit become detached electrically from the rest of the Grid System . This detached System with its associated Networks and Generating Units is an Islanding .
Isolation	<p>The disconnection of Plant and Apparatus from the remainder of the System in which that Plant and Apparatus is situated by isolating Device maintained in an isolating position.</p> <p>The isolating position must either be:</p> <ul style="list-style-type: none"> (i) Maintained by immobilising and Locking the Isolating Device in the isolating position and affixing a Caution Notice to it. Where the Isolating Device is Locked with a Safety Key, the Safety Key must be secured in a Key Safe and the Key Safe Key must be retained in safe custody; or (ii) Maintained and/or secured by such other method which must be in accordance with the Local Safety Instructions of SESB or the User, as the case may be.
Isolating Device	An approved device for rendering Plant and Apparatus into an Isolated condition.
Licence	A licence issued under section 8 of the Enactment and includes any licence issued under any other law enforced before the promulgation of the Enactment.

Term	Definition
Licence Standards	The standards covering Distribution System security, power quality and operation and maintenance and any other standards produced under the terms of the Distributor's Licence and approved by the Commission .
Licencee	A person licenced under section 8 of the Enactment
Low Voltage	A voltage normally exceeding extra low voltage but not exceeding 1,000 volts alternating current or 1,500 volts direct current between conductors, or 600 volts alternating current or 900 volts direct current between conductor and earth
Medium Voltage	A voltage normally exceeding low voltage but equal to or not exceeding 50 000 volts.
Meter	A device for measuring and recording produced or consumed units of Active Energy and Reactive Energy and/or Active Power and/or Reactive Power and/or Demand .
Metering	The process of measuring and recording the production or consumption of electrical energy.
Minister or the Minister	The Minister for the time being charged with the responsibility for matters relating to the supply of electricity.
Network	A general expression for a Transmission Network and/or, Distribution Network and/or User Network as the case may be. In certain instances, it means all of these networks.
Operation	A scheduled or planned action relating to the operation of a System .
Operational Planning	The procedures set out in the Distribution Operating Code comprising, through various timescales, the planning and co-ordination of the operation of the Distribution System and associated planned outages and Demand forecasting.

Term	Definition
Ownership Boundary	The electrical boundary between the Equipment owned by a Distributor or Embedded Distributor and the Equipment owned by a User or the Equipment owned by the Transmission System Owner
Partial Blackout	The same as a Total Blackout except that all generation has ceased in a separated part of the Total System and there is no electricity supply from External Interconnections or other parts of Total System to that part of Total System with the result that the separated part of the Total System is unable to operate normally and is shut down.
Peak Demand	The highest level of Demand recorded/forecast for a 12-month period, as specified in the relevant sections of the Distribution Code .
Person	Shall be any individual corporation, partnership, joint venture, trust, unincorporated organization or government (or any agency, instrumentality or political subdivision thereof)
Phase Unbalance	A general term relating to the difference in the magnitude of the three individual phase voltages due to the imbalance in the magnitude of the Demand (Load) or own generation, connected to each one (1) of the three (3) phases.
Plant	Fixed and movable items used in the generation and/or distribution and/or transmission of electricity other than Apparatus .
Point of Common Coupling (PCC)	The point on the Distribution System , electrically closest to the User's Connection Point , at which other Users supplies are connected.
Power Factor	Ratio of Active power to Apparent power
Protection	The provisions for detecting abnormal conditions in a System and initiating fault clearance or actuating signals or indications.

Term	Definition
Reactive Energy	The reactive energy produced, flowing or supplied by an electric circuit during a time interval, being the integral with respect to time of the instantaneous Reactive Power and normally measured in kiloVar-hour (kVArh) or megaVar-hour (MVArh).
Reactive Power	The product of voltage and current and the sine of the phase angle between them which are normally measured in kiloVar (kVAr) or megaVar (MVA).
Registered Capacity	The normal full load capacity of a Generating Unit as declared by the Generator , less the MW consumed when producing the same; ie for all Generators , including Customer With Own Generation , this will relate to the maximum level of Active Power deliverable to the Distributor's Distribution System . For Generating Units connected to the Distributor's Distribution System via an inverter, the inverter rating is deemed to be the Generating Unit's rating.
Registered Data	Data referred to in the schedules to the Distribution Data Registration Code .
Revenue Metering	The systems of meters and associated Equipment installed for measuring Active Power , Reactive Power , Active Energy and Reactive Energy for the purposes of settling accounts for electricity flows between Users and the Distribution System
Rural Distribution System	MV system that has feeder length of more than 50km from its original source of supply. The original source of supply is a location where the system voltage can be regulated automatically
SAIDI	System Average Interruption Duration Index for all types of interruptions. This distribution reliability index sometimes referred to as Average Customer Minutes or Customer Hours Lost provides information about the average time customers are interrupted.

Term	Definition
Sabah Distribution Control Centre (SDCC)	Person(s) responsible for the control and operation of all, or of part of a Distribution System , or the System of a User which operates at Medium Voltage .
SAIFI	System Average Interruption Frequency Index for sustained interruptions. The objective of this distribution reliability index is to provide information about the average frequency of sustained interruptions per customer.
SEDA	Sustainable Energy Development Authority Malaysia
SESB	Sabah Electricity Sdn. Bhd is a Licencee that owns and operates electricity generation, transmission and distribution facilities and provides retail sale of electricity to Consumers in the state of Sabah.
SESB Transmission	Part of the SESB Asset Management engaged in transmission operation and maintenance activities.
Significant Incident	An Operation or Event on the Transmission System or Distributor's Distribution System or a User's System which has or may have a significant effect on the System of others.
Single Buyer	A division of the SESB Asset Development responsible for managing Power Purchase Agreements and Settlement process.
Standby Supply	The supply of electricity by a Distributor to a Consumer With Own Generation (CWOG) on a periodic or intermittent basis to make good any shortfall between the CWOG's total supply requirements and that met by his own generation.
System	Means an electrical system in which all conductors and Equipment are electrically or magnetically connected.

Term	Definition
Top-Up Supply	The supply of electricity by any Distributor to a Consumer With Own Generation (CWOG) on a continuing or regular basis to make good any shortfall between a CWOG's total supply requirements and that met from other sources.
Total Blackout	The situation existing when all generation has ceased and there is no electricity supply with the result that the Total System is unable to operate normally and has shutdown with the result that it is not possible for the Total System to begin to function again without directions from the GSO directions relating to a Black Start .
Total Harmonic Distortion	Harmonic distortion is the departure of a waveform from sinusoidal shape that is caused by the addition of one or more harmonics to the fundamental. Total Harmonic Distortion is the square root of the sum of the squares of all harmonics expressed as a percentage of the magnitude of the fundamental.
Total System	The Transmission System , all Distribution Systems and User Systems .
Transformer Operated Metering	Revenue Metering Equipment that measures the quantity of electricity supplied by measurement of the parameters of current and voltage via current transformers and/or voltage transformers.
Transmission System	The system of electric lines with voltage levels at or above 66 kV owned or operated by the transmission system Licencee .
User	A term used in various sections of the Distribution Code to refer to the persons using the Distributor's Distribution System , more particularly identified in each section of the Distribution Code , but excluding the Transmission System Licencee or Grid System Operator .
Whole Current Metering	Revenue Metering Equipment that measures the quantity of electricity supplied by direct measurement of the parameters of voltage and current.

Introduction

3.1 Objectives

- 3.1.1 The objectives of this Introduction are to describe the following:
- a) The scope of the **Distribution Code**.
 - b) Parties affected by the **Distribution Code**.
 - c) The purpose of the **Distribution Code**.
 - d) Matters relating to the establishment of the **Distribution Code** and **Distribution Code** governance.
 - e) The contents of the **Distribution Code**.

3.2 Scope

- 3.2.1 The **Distribution Code** applies to holders of **Licence** for the distribution of electricity (**Distributors**) and to parties connected directly or indirectly to the **Distribution System**, i.e., **Large Power Consumers**, **Embedded Distributors**, and **Distributed Generators**, in the **Distribution Code** collectively termed **Users** (of the **Distribution System**).
- 3.2.2 The **Distribution Code** specifies technical requirements relating to connection to and use of the **Distribution System** which ensure compliance by all **Distributors**, **Embedded Distributors**, **Distributed Generators** and **Large Power Consumers** with the **Electricity Supply Laws** and with the **Distributor's Licence** and the **Grid Code**.

3.3 Purpose of Distribution Code

- 3.3.1 The purposes of the **Distribution Code** are to:
- a) Specify the normal technical parameters and requirements for design and operation of the **Distribution System** and to make these transparent to **Users**.
 - b) Specify the technical requirements for connection to the **Distribution System** for each class of **User** so that the **Distributor** is able to design, operate and maintain the **Distribution System** in compliance with its **Licence** and the **Electricity Supply Laws** and to ensure equal access to the **Distribution System** by all **Users**.
 - c) Specify the data exchange requirements between **Users** and **Distributors** so that the **Distributor** and **User** have sufficient information to enable them to design and operate their respective

installations in line with the **Electricity Supply Laws** and **Licence** and to enable the **Distributor** to make an offer to the **User** for connection to the **Distribution System**.

- d) To enable the **Distributor** to comply with relevant provisions of the **Grid Code**.

Annex 1 of the **Distribution Code** includes, for information, the **Licence Standards**, covering technical matters prepared by **Distributors** with concurrence of the **Commission** in accordance with the terms of Licence.

3.3.2 The **Distribution Code** is designed to protect the interests of **Users** and provide for transparency and non-discrimination in technical matters related to electricity supply in Sabah.

3.3.3 The **Distribution Code** establishes the technical requirements for providing the normal standard electric distribution service from **Distributors** in order to have an efficient, uniform and consistent basic service from all **Distributors**. This does not preclude **Users** from specifying an enhanced service where available.

3.3.4 Performance requirements such as **SAIDI** and **SAIFI** are not specified in the **Distribution Code** as these are closely linked to investment requirements and tariffs and incentives approved by the **Commission**. However, **Licences** require each **Distributor** to specify the criteria for measuring performance for concurrence by the **Commission** as a **Licence Standard** and to provide an annual report on performance of the **Distribution System**.

3.4 Governance Arrangements

3.4.1 Establishment of the Distribution Code

3.4.1.1 **Distribution Code** for Sabah specifies the normal technical requirements suitable for all **Distribution Systems**, **Embedded Distribution Systems**, **Users**, and it:

- a) Covers all material technical aspects relating to the planning, operation and connection to the **Distribution System** and the operation of electric lines and electrical **Plant and Apparatus (Equipment)** connected to the **Distributor's Distribution System**; and

b) is designed so as to:

- i) Permit the development, operation and maintenance of an efficient, coordinated and economical system for the distribution of electricity.
- ii) Facilitate competition in the generation and supply of electricity.
- iii) Ensure nondiscrimination in the provision of connection to and use of the **Distribution System**

3.4.1.2 It is the legal obligation of each **Distributor** and **User** to comply with the provisions of the **Distribution Code** as modified through grant of derogations/exemptions to the concerned Distributor/User.

3.4.1.3 The **Commission** has the responsibility for approving the **Distribution Code** including all modifications, and for overseeing compliance of the Code by **Distributors, Distributed Generators** and all **Users**.

3.4.1.4 **Distributors, Distributed Generators** and **Consumers** shall comply with the **Distribution Code**. **Embedded Distributors** shall also comply with the **Distribution Code** in respect of the **Embedded Distributors'** own **Distribution Systems** and also as **Users** of the **Distributor's Distribution System**. Consumers of Embedded Distributors shall comply with the **Distribution Code** in respect of the **Embedded Distributors'** **Distribution Systems**.

3.4.1.5 In the case of **Consumers** connected to the **Distribution System** at **Low Voltage**, the **Distributor** has a duty to implement procedures for connection to the **Distribution System**, which ensure that those **Consumers** connected at **Low Voltage** comply with the **Distribution Code**. Other **Users** have an unconditional obligation to comply with the **Distribution Code**.

3.4.1.6 The **Commission** shall establish a **Distribution Code Committee** with representation from **Distributors** and **Users** for management of the **Distribution Code**. Composition and functions of the Distribution Code Committee are provided in the Chapter "**Distribution General 22 Conditions**".

3.4.1.7 The obligations of the **Committee** and representation on the **Committee** are covered in **Distribution General Conditions (DGC)** and the rules of the **Committee** are set out in Annex 3.

3.4.2 Legacy arrangements, Derogations and Exemptions:

3.4.2.1 Prior to establishing the **Distribution Code**, **Licences** have been awarded to **Distributors** which have resulted in Power Purchase Agreements and other **Connection Agreements** which may be at variance with some provisions of the **Distribution Code**. Nothing contained in the **Distribution Code** is intended to modify, replace or negate the existing requirements and obligations established in Power Purchase Agreements and **Connection Agreements**. The **Distribution Code** is intended to complement and clarify the intent and requirements of those previously issued documents. In the event of any conflict, the original agreements take precedence only to the extent that they do not affect the safety and security of the **Distribution System**.

3.4.2.2 The **Commission** may grant **Distributors** or **Users** derogations or exemptions to defined provisions of the **Distribution Code** in certain situations where the impact is acceptable to the **Distributor** and the **Commission**. Derogations will be for a specified period of time, with or without conditions or any mitigation measures required. Exemptions will be for an indefinite period of time with or without conditions or mitigation measures.

3.4.2.3 All **Connection Agreements** after the implementation of the **Distribution Code** shall specify that it is a requirement for the **User** to comply with the **Distribution Code**.

3.4.2.4 Section 4.9 of the Distribution General Conditions provides the details for grant of derogations/exemptions.

3.4.3 Disputes

3.4.3.1 A dispute within the **Committee** and/or from public consultation on the provisions of the **Distribution Code** is resolved by the **Committee** reporting to the **Commission** for resolution of the dispute by the **Commission**. The report shall contain details of the matter that is in dispute and the implications for the provision of electricity supplies and the impact on the **Distributor** and **Users**.

3.4.3.2 Disagreements and disputes may arise between parties in the interpretation and application of the provisions of the **Distribution Code**. Parties are urged to settle disputes between themselves promptly and fairly as they arise. If a **Distribution Code** related dispute between a **Distributor** and **User** cannot be resolved, then the matter may be referred to the **Commission** for a decision. The **Commission** may then seek advice from the **Committee** on any dispute on interpretation of the **Distribution Code**. The **Commission** shall decide on the dispute and make an order accordingly. The **Commission** may decide to take assistance of sector/legal experts, as required for arriving at a decision. The procedure to be followed in the resolution of any dispute shall be determined by the **Commission**.

3.5 Description of the Contents of the Distribution Code

3.5.1 Sections of the Distribution Code

3.5.1.1 The **Distribution Code** is organized into ten sections as described in the following paragraphs.

3.5.1.2 **Section 1, PREFACE** - The Preface provides brief background information on the **Electricity Supply Industry** in Sabah, the electricity **Distribution** functions, the requirements for **Licence Standards**, the need for the **Distribution Code** and a summary of the contents of the **Distribution Code**.

3.5.1.3 **Section 2, DISTRIBUTION GLOSSARY AND DEFINITIONS (DGD)**
- The **DGD** provides descriptions and meanings of technical and other words or expressions used in the **Distribution Code**. In general, the meanings are the same as or derived from those provided in the **Electricity Supply Laws** and **Licences**.

3.5.1.4 **Section 3, INTRODUCTION** - The Introduction describes the scope and purpose of the **Distribution Code** and the establishment of the **Distribution Code** and its governance and implementation, including requirements for compliance with the **Distribution Code** by **Distributors** and **Users**.

- 3.5.1.5 **Section 4, DISTRIBUTION GENERAL CONDITIONS (DGC)** - The **DGC** covers legal interpretation and specifies the governance arrangements of the **Distribution Code** through the **Distribution Code Committee** to ensure that the **Distribution Code** is maintained up to date as an ongoing working document. The detailed rules for the **Distribution Code Committee** are set out in Annex 3. The **DGC** also sets out arrangements for unforeseen circumstances and emergencies and covers some matters that are relevant to all sections of the **Distribution Code**.
- 3.5.1.6 **Section 5, DISTRIBUTION PLANNING CODE (DPC)** - The **Distribution Planning Code** sets out the requirements for planning the **Distribution System** to ensure that the **Distribution System** is planned within the **Electricity Laws** and **Licences** to provide an economic, efficient and co-ordinated electricity supply system. The **DPC** focuses on the normal requirements of supply to **Users** and includes **Demand** forecast data requirements and arrangements for forward planning of the **Distribution System**. The **DPC** also sets out the security and quality of supply characteristics and limits of the **Distribution System** and how these are achieved by cross reference to the **Distributor's Licence Standards** where appropriate.
- 3.5.1.7 **Section 6, DISTRIBUTION OPERATING CODE (DOC)** - The **Distribution Operating Code** specifies the requirements for operation of the **Distribution System** focusing on co-ordination of safety and operation and maintenance at points of interfaces between **Distributors** and **Users** to ensure that the **Distribution System** is operated within the **Electricity Laws** and **Licences** to provide an economic, efficient and co-ordinated electricity supply system.
- 3.5.1.8 **Section 7, DISTRIBUTION CONNECTION CODE (DCC)** - The **Distribution Connection Code** specifies the technical requirements for connection of **Users** to the **Distribution System** to ensure uniformity and co-ordinated connections and compliance with the provisions of the **DPC** and **DOC**. The **DCC** also specifies the data exchange requirements for new or modified connections of **Users** of the **Distribution System**.
- 3.5.1.9 **Section 8, DATA REGISTRATION CODE (DRC)** - The **DRC** specifies the requirements for registering data interchanged between **Distributors** and **Users** and where appropriate specifies standard schedules for recording data exchanged.

- 3.5.1.10 **Section 9, METERING CODE** - The **Distribution Metering Code (DMC)** sets out the technical requirements for **Revenue Metering** at the interface between **Distributors** and **Users**.
- 3.5.1.11 **Section 10, SPECIFIC REQUIREMENT FOR SABAH**– The Specific code for Sabah describe special clauses to address specific concerns in the Sabah Distribution System.
- 3.5.2 **Annexes of the Distribution Code**
- 3.5.2.1 The following are the annexes to the **Distribution Code**.
- 3.5.2.2 **Annex 1, Distributor’s Licence Obligations** - The **Licences** issued to each **Distributor** include conditions for **Distributors** to develop and adopt certain technical standards (**Licence Standards**) with the concurrence of the **Commission**.
- 3.5.2.3 **Annex 2, Electrical Standards** - Annex 2 lists the technical standards referred to in the **Distribution Code** other than the **Licence Standards** that are listed in Annex 1.
- 3.5.2.4 **Annex 3, The Rules of the Distribution Code Committee** – Annex 3 contains rules of the **Distribution Code Committee**.

Distribution General Conditions

4.1 Introduction

4.1.1 Each section within the **Distribution Code** contains provisions relating to that particular section. The **General Conditions** contain provisions that are of general application to all sections of the **Distribution Code**. The objective is to ensure, to the extent possible, that the various sections of the **Distribution Code** work together and work in practice for the benefit of all **Users**.

4.1.2 The **General Conditions** also specify the arrangements for the **Distribution Code Committee**, which requires representation from **Users** and therefore provides transparency to the development of the **Distribution Code**. The **Commission** approves the provisions of the **Distribution Code** and this provides independence to the governance of the **Distribution Code**.

4.2 Scope

4.2.1 The **General Conditions** apply to the **Distributor** and all **Users** including, for the avoidance of doubt, **SESB** as a **Distributor** and as a **Distributed Generator**.

4.3 Objectives

4.3.1 The objectives of the **General Conditions** are as follows:

- a) to ensure, to the extent possible, that various sections of the **Distribution Code** work together for the benefit of the **Users**; and
- b) to provide a set of principles for governing the development of the **Distribution Code**.

4.4 Interpretation

4.4.1 In this **Distribution Code**, unless the context otherwise requires:

- (a) References to “the **Distribution Code**” or “this **Distribution Code**” are with reference to the whole of the **Distribution Code**, including any schedules or other documents attached to any part of the **Distribution Code**.
- (b) The singular includes the plural and vice versa.

- (c) Any reference to one gender includes the other.

4.4.2 In this **Distribution Code**, references to codes, paragraphs, clauses or schedules are specifically to those codes, paragraphs, clauses or schedules of this **Distribution Code**.

4.4.3 In this **Distribution Code**,

- i) The section paragraph and schedule headings are for convenience and reference only and do not form part of the **Distribution Code**.
- ii) Reference to any law, regulation made under any law, standard, secondary legislation, contract, agreement or other legal document shall be to that item as amended, modified or replaced from time to time. In particular any reference to any **Licence** shall be to that **Licence** as amended, modified or replaced from time to time and to any rule, document, decision or arrangement promulgated or established under that **Licence**.
- iii) References to the consent, approval or concurrence of the **Commission** shall be references to the approval, consent or concurrence of the **Commission** in writing, which may be given subject to such conditions as may be determined by the **Commission**, as that consent, approval or concurrence may be amended, modified, supplemented or replaced from time to time and to any proper order, instruction or requirement or decision of the **Commission** given, made or issued under it.
- iv) All references to specific dates or periods of time shall be calculated according to the Gregorian calendar and all references to specific dates shall be on the day commencing on such date at 00:00 hours.
- v) Where words or expressions are defined in this **Distribution Code**, cognate words and expressions shall be construed accordingly.
- vi) References to “person” or “persons” include individuals, firms, companies, state government agencies, federal government agencies, committees, departments, ministries and other incorporate or unincorporated bodies as well as to individuals with a separate legal personality or not.
- vii) The words “such as”, “include”, “including”, “for example” and “in particular” shall be construed as being by way of illustration or emphasis and shall not limit or prejudice the generality of any foregoing words.

4.5 **Distribution Code Committee (DCC)**

4.5.1 The Commission shall establish the Distribution Code Committee, which shall be a standing committee, and carry out the functions referred to in paragraph 4.5.3.

4.5.2 The **Committee** shall not have any obligations towards **Licence Standards** adopted by each **Distributor** with the concurrence of the **Commission**, and listed in Annex 1.

4.5.3 The Distribution Code Committee shall:

- (a) Review the implementation of the Distribution Code
- (b) Review all suggestions for amendments to the **Distribution Code** which the **Commission**, or any **User** or **Distributor** may wish to submit for consideration by the **Committee** from time to time. Publish recommendations, for public consultation, as to amendments to the **Distribution Code** that the **Committee** or any **Distributor** considers necessary or desirable and the reasons for the recommendations.
- (c) Provide guidance in relation to the **Distribution Code** and its implementation, performance and interpretation when asked to do so by the **Distributor**, any **User** or the **Commission**.
- (d) Consider what changes are necessary to the **Distribution Code** arising out of any unforeseen circumstances referred to it by any **Distributor** under **DGC** Section 4.6.

4.5.4 The Committee shall consist of members representing Distributors and Users of the Distribution System and observers from interested parties in accordance with the following requirements. (Committee members may also serve on the Grid Code Committee).

Member	Sabah
SESB Distribution Division	3
Other Distributors	2
Embedded Distributors	2
Distributed Generators	2
Regional Control Centres	2
Consumer	1
Commission	1
Grid System Operator	1
SESB Transmission Division	1
SESB Planning Division	1
Any other party as an observer or a member whom the Committee feels necessary	As necessary

All members of the Distribution Code Committee shall be approved by the Commission. The Committee will be chaired by a Senior Officer of the Commission having adequate technical background.

4.5.5 The **Distribution Code Committee** shall establish and comply at all times with its own rules and procedures relating to the conduct of its business, which rules and procedures shall be approved by the **Commission** and are set out in Annex 3.

4.6 Unforeseen Circumstances

4.6.1 If circumstances not envisaged by the provisions of the **Distribution Code** should arise, the **Distributor** shall, to the extent reasonably practicable in the circumstances, consult promptly and in good faith with all affected **Users** in an effort to reach agreement as to what should be done. If agreement between the **Distributor** and those **Users** cannot be reached in the time available, the **Distributor** shall determine what is to be done.

4.6.2 Wherever the **Distributor** makes a determination, it shall do so having regard, wherever possible, to the views expressed by **Users** and, in any event, to what is reasonable in all the circumstances. Each **User** shall comply with all instructions given to it by the **Distributor** following such a determination provided that the instructions are consistent with the then current technical parameters of the particular **User's System**. The **Distributor** shall promptly refer all such unforeseen circumstances and any such determination to the **Distribution Code Committee** for consideration in accordance with 4.5.3(e).

4.7 Emergency Situations

4.7.1 The provisions of the **Distribution Code** may be suspended in whole or in part during emergency situations by order of the **Commission** so that the **Distributor** may safeguard electricity supplies in the national interest or for public safety, in consultation with the **Commission**.

4.8 Non-Discrimination

4.8.1 The **Distributor**, in implementing and complying with the **Distribution Code** as well as scheduling maintenance on its system, shall not unduly discriminate against or unduly prefer in favour of or against:

(a) Legacy any one person or any group of persons, or

- (b) the **Distributor** in the conduct of any business other than the Distribution business.

4.9 Arrangements and Derogations

- 4.9.1 It is the sole responsibility of a User to certify the continual compliance of all the provisions of the Distribution Code. In cases where he is unable to comply with any provision of the Distribution Code, then it shall, without any delay, report such non-compliance to **Commission** and the Distributor. It is important for the Distributor to be informed of every non-compliance as non-communication of this non-compliance may result in the Distributor taking operational decisions which may jeopardise integrity and safety of the Distribution System.
- 4.9.2 The User will discuss with the Distributor the proposed remedy to restore compliance and the Distributor will identify the operational measures required to ensure secure operation of the Distribution System. The User and the Distributor will then submit the agreed solution and time scales to complete the reasons for non-compliance to **Commission** for approval. **Commission** will then issue the appropriate temporary derogation after consultation with the Distribution Code Committee, with a time limit, to the User and request the Distributor and the User to report progress of the remedy.
- 4.9.3 On completion of the remedy within such time limit, the temporary derogation will be withdrawn by **Commission**. This process should be completed on an urgent basis so that all measures to the remedy are in place and the additional costs to the system are minimized.
- 4.9.4 The provision of a technical derogation or exemption does not release the derogated party from compliance with the provisions of any commercial agreement or from any commercial liability arising from such technical derogation or exemption. Likewise, the provision of a technical derogation or exemption does not excuse the derogated party from compliance with any instruction from the Distributor in circumstances where the Distributor makes a finding that non-compliance by the derogated party in such circumstances may affect the safety and security of the Distribution System.

- 4.9.5 The non-compliance may be with reference to Plant and Apparatus:
- i. which is already connected to the Distribution System and is caused by solely or mainly as a result of a revision to the Distribution Code;
 - ii. which is already connected to the Distribution System and is caused by a developed or developing partial defect and where the Plant and Apparatus may remain operable albeit with some operational constraints or at reduced capability; and
 - iii. which is seeking approval for connection to the Distribution System.

4.9.6 In cases where a User believes that remedying such non-compliance is unreasonable for technical or financial reasons or requires an extended period to remedy such non-compliance, it shall promptly submit a request to **Commission** with a copy to the Distributor for a full Derogation from remedying or an extension to the period for implementing the remedy.

4.9.7 If the Distributor finds that it is or will be unable to comply with any provision of the Distribution Code at any time, then it shall notify **Commission** promptly.

4.9.8 A request for derogation from the Distributor or a User shall contain:

- i. reference to the particular Distribution Code provision against which the particular non-compliance or the predicted or developing non-compliance was identified;
- ii. the particulars of the Plant and/or Apparatus in respect of which a derogation is being sought;
- iii. the reason, nature, extent and impact of the non-compliance;
- iv. the probable period of non-compliance and the times in which full compliance would be achieved; and
- v. the reason for and impact of extended periods of non-compliance if full compliance cannot be achieved for technical or financial reasons.

4.9.9 The **Commission** may reject the request giving reasons for the same or it may accept it for consideration. The **Commission** shall examine the requests which are for consideration and discuss them with the Distributor, the User, the Distribution Code Committee and the GSO (if the derogation is likely to affect the Transmission System). In considering granting the derogation, **Commission** would fully take into account the views of the Distributor and the Distribution Code Committee on whether the derogation would, or is likely to:

- i. have material and adverse impact on the security and/or stable operation of the Distribution System; or

- ii. impose high or unreasonable costs on the operation of the Distribution System.
- 4.9.10 Dependent upon the nature of the Derogation being sought a temporary Derogation with a time limit or a long-term Derogation or Exemption maybe granted by **Commission**.
- 4.9.11 While considering a Derogation request by the Distribution Owner or a User, **Commission** may seek all necessary clarification and external expert assistance in making his determination.
- 4.9.12 To the extent of any Derogation granted to the User and/or the Distributor, the party or parties shall be relieved from any obligation to comply with the applicable provision of the Distribution Code and shall not be liable for failure to comply but shall comply with any alternative provisions specified in the Derogation.
- 4.9.13 It is the duty of both the Distributor and **Commission** to keep comprehensive records of all derogations granted with respect to the Distributor and/or the Users. These records shall contain detailed account of the nature of the Derogation and its effective period.
- 4.9.14 It is the duty of both the Distributor and **Commission** to annually review existing derogations and take into account of any material changes in the circumstances if such a change has occurred.
- 4.9.15 The Distributor and/or Users may request a review of any existing Derogation.
- 4.9.16 The **Commission** may consider hosting the following on its website:
- i) Details of all applications for grant of derogation/exemption received
 - ii) Orders related to above.

4.10 Confidentiality

- 4.10.1 The **Distributor** shall maintain the confidentiality of all data provided by a **User** to meet the requirements of the **Distribution Code** and may only pass on data to other parties when authorized to do so by that **User**; except that the **Distributor** may pass on information to the **GSO** to meet the requirements of the **Grid Code**. An **Embedded Distributor** may also pass on data to the relevant **Distributor** to meet the requirements of the **Distribution Code**.

4.11 Notices and Communication

- 4.11.1 Unless otherwise specified in the **Distribution Code**, the methods of operational communication (other than relating to the submission of data and notices) shall be as agreed between the **Distributor** and **User** from time to time.
- 4.11.2 Data and notices that are required to be exchanged between the **Distributor** and **User** under the **Distribution Code** (other than data which is the subject of a specific requirement of the **Distribution Code** as to the manner of its delivery) shall be delivered in writing.
- 4.11.3 References in this **Distribution Code** to “in writing” or “written” include printing, and other modes of reproducing words in a legible and non-transitory form and, except where otherwise stated, includes suitable means of electronic transfer, such as electronic mail. In all cases the form of notification and the nominated persons or departments and addresses of the sender and recipient of the data or information shall be agreed by the **Distributor** and **User** and the sender shall be able to confirm receipt of the information by the recipient. In the case of electronic transfer, the sender and recipient shall be able to reproduce the information in non-transitory form.

Distribution Planning Code

5.1 Introduction

5.1.1 The **Distribution Planning Code (DPC)** sets out the requirements for planning the **Distribution System** focusing on normal requirements of supply to **Users**. The **DPC** sets out the security and quality of supply characteristics and limits of the **Distribution System** and how these are achieved by cross reference to the **Distributor's Licence Standards** where appropriate. The **DPC** also includes **Demand** forecast data requirements for forward planning of the **Distribution System** and the **Transmission System**.

5.1.2 Expansion and reinforcement of the **Distribution System** needs to be carried out regularly by each **Distributor** for several reasons including, but not limited to:

- (a) Network expansion to meet **Users' Demand**;
- (b) Network reinforcement to satisfy supply performance requirements;
- (c) Connection of **Users** to the **Distribution System**;
- (d) An introduction or reinforcement of a transmission bulk supply substation; and
- (e) Establishment of connections between **Distributors**.

5.1.3 The lead-time for planning implementation depends on the type and scale of network expansion and/or reinforcement, and the need or otherwise to obtain statutory approvals or other consents. Therefore, **Distributors** and **Users** involved shall allow for a reasonable time period for exchanging of planning information and performing of the necessary planning studies and obtaining consents for implementation.

5.2 Scope

5.2.1 The **DPC** applies to the **Distributor, Consumers, Distributed Generators, and Embedded Distributors** connected to the **Distributor's Distribution System**. All **Distributors** and **Users** connected to the **Distributor's Distribution System** shall comply with the requirements of the **DPC**.

5.3 Objectives

5.3.1 The objectives of the Distribution Planning Code are:

- (a) to enable the **Distributor's Distribution System** to be planned and designed so that the **Distribution System** operates within the supply performance and safety requirements specified in the **DPC** and **Electricity Supply Laws and Licence**;
- (b) to specify the security, quality of supply and the limits of frequency, voltage regulation and voltage characteristic normally provided by the **Distributor's Distribution System**;
- (c) to specify planning criteria and supply performance requirements to be used and satisfied by the **Distributors** during the planning stage;
- (d) to specify requirements for determining **Demand** forecasts by the **Distributors** and **Users** connected to the **Distributor's Distribution System**; and
- (e) to establish requirements for provision of planning information from the **Distributor** and **Users**.

5.4 Planning and Design Criteria

5.4.1 General

5.4.1.1 Each **Distributor** shall ensure that its **Distribution System** conforms to the provisions of the **Electricity Supply Laws** and conditions in the **Licence** placed on the **Distributor**.

5.4.1.2 The main objective of this section of the **DPC** is to outline normal requirements for the **Distributor** to comply with when assessing performance during the planning stage. These are basic requirements and do not prevent the **Distributor** from applying a higher performance standard than specified in this section.

5.4.1.3 The **Distributor** shall plan, develop and design its **Distribution System** according to the requirements not less than set in this section using the best engineering and prudent utility practices in so far as applicable. It is important to note that planning and design criteria are sets of requirements to be satisfied at the planning stage. These sets of criteria may or may not be the same as those required under operating situations.

- 5.4.1.4 Nothing in this **DPC** is intended to inhibit design innovation.
- 5.4.1.5 Where the **Distributor** is required by its **Licence** to produce and implement a **Licence Standard** covering the security and quality of supply, or other matters relevant to this **DPC** for the concurrence of the **Commission**, then the **Licence Standard** shall meet the normal requirements specified in this **DPC** and be published in Annex 1 of the **Distribution Code**.
- 5.4.1.6 Other standards referred to in this **DPC** are listed for convenience in Annex 2 of this **Distribution Code**.
- 5.4.2 **Security Standards**
- 5.4.2.1 Supply security of a **Distribution System** defines the availability of supply to **Users** following the occurrence of a supply interruption.
- 5.4.2.2 The level of security to be provided in the design of the **Distribution System** is as set out in **DPC** provision 5.4.2.3 with modifications as granted through derogation(s) for a particular Distributor/User.
- 5.4.2.3 The normal level of security for design of the **Distribution System** shall be as follows:
- (a) Sections of the **Distribution System** supplied at **Medium Voltage** will normally be provided with alternative circuits and/or other facilities such that for a single circuit outage, excepting a busbar outage, supplies shall be restored within a period of up to 4 hours, except that those parts of the **MV Distribution System** in areas of low load density or having a **Peak Demand** of less than 1 MW, may be restored in the time taken to repair or restore that part of the **Distribution System**, with a target restoration time of not more than 24 hours.
 - (b) Sections of the **Distribution System** supplied at **Low Voltage** shall be restored following an outage within the time taken to repair or restore that part of the **Distribution System** with a target restoration time of not more than 24 hours.
 - (c) In the case of **Force Majeure** restoration may be delayed beyond 24 hours for the time taken to carry out repairs.
 - (d) For Rural Distribution System in Sabah, refer to Section 10.4.

- 5.4.2.4 In designing the **Distribution System** to meet this normal security standard, the **Distributor** shall meet the following requirements:
- i) During normal operation of the **Distribution System** and for any secured single circuit outage the loading on the **Distribution System** shall be maintained within the continuous ratings of the **Distribution Equipment** and the voltage shall be maintained within the limits specified in this **DPC**.
 - ii) The **Distributor** shall not take into account the output of any **Distributed Generating Unit** in maintaining the normal standard of security of supply.
- 5.4.2.5 Where a **Distributor** is required by **Licence** to produce and implement a **Licence Standard** covering security of supply then the security standard shall not be lower than provision 5.4.2.3.
- 5.4.2.6 The normal level of security required by provision 5.4.2.3 does not preclude the **Distributor** from adopting a higher level of security on a non-discriminatory basis.
- 5.4.2.7 The normal level of security specified in provision 5.4.2.3 does not apply to the circuit that connects the **User's** installation to the **Point of Common Coupling (PCC)** with other **Users** of the **Distribution System**. The security level for such circuits may be specified by the **User** and provided by the **Distributor** on a non-discriminatory basis in line with the **Distributor's** statement on connection charges required by the **Licence** and according to the **Users** requirements, with the following qualifications:
- (a) The normal supply arrangement to a **Consumer** or **Distributed Generator** is for a single circuit supply from the **PCC** unless the **Consumer** or **Distributed Generator** requests a higher level of security.
 - (b) The supply connection to an **Embedded Distributor** and its **DG** or **Consumer With Own Generation (COWG)** shall be that required to meet the normal security standard specified in provision 5.4.2.3 or a higher standard requested by the **Embedded Distributor** to meet the **Embedded Distributor's Licence Standard** or other standard adopted by the **Embedded Distributor**.
 - (c) The connection charges for CWOOG may defer from connection charges of normal consumers

5.4.3 System Frequency

5.4.2.8 During normal steady-state operational conditions the **System** frequency is maintained by the **Grid System Operator** to within $\pm 1\%$ of the nominal value of 50Hz, that is, between 49.5Hz and 50.5Hz. The **System** frequency could also rise to 52Hz or fall to 47Hz in exceptional circumstances.

5.4.2.9 The **Distributor's Distribution System** and any **User** connections to that **Distribution System** shall be designed to operate within the normal operating frequency range of 49.5Hz and 50.5 Hz and withstand short time operation within the range 47Hz and 52 Hz.

5.4.4 Steady-State Supply Voltage Variation

5.4.4.1 Steady-state Voltage Variation under Normal conditions

5.4.4.1.1 Under normal conditions, when all circuit elements are in service, the voltage at all points in the **Distributor's Distribution System** including the points before the **Users Connection Point** shall be planned to be maintained as follows:

- (a) **Medium Voltage** of 11 kV, and 33 kV within $\pm 5\%$ of nominal voltage; and
- (b) **Low Voltage** of 400 V and 230 V within $+10\%$ and -6% of nominal voltage.

5.4.4.2 Steady-state Voltage Variation under Contingency Condition

5.4.4.2.1 Under contingency condition, when one or more circuit elements are on outages, the steady-state voltage at all points in the **Distributor's Distribution System** including the points before the **User's Connection Point** shall be planned to be maintained as follows:

- (a) **Medium Voltage** of 11 kV, and 33 kV within $\pm 10\%$ of nominal voltage; and
- (b) **Low Voltage** of 400 V and 230 V within $+10\%$ and -6% of nominal voltage.

5.4.4.3 **Steady-State Voltage Variation at the Interfaces With Transmission Bulk Supply Substation**

5.4.4.3.1 In planning the **Distribution System** involving interface with the **Transmission System**, the **Distributor** shall take into account steady- state voltage variation limits as specified in provision CC6.2.4 of the **Grid Code**.

5.4.4.3.2 Any extension or connection to the **Distributor's Distribution System** shall be designed in such a way that it does not adversely affect the voltage control employed on the **Distributor's Distribution System**. Information on the voltage regulation and control arrangements on the **Distribution System** will be made available by the **Distributor** to the **User** on the request of the **User**.

5.4.5 **Short Duration Supply Voltage Variation**

5.4.5.1 Short duration supply voltage variations include voltage dips, voltage swells, momentary interruptions, temporary interruptions and transients in Distribution Systems and these events are part of the electromagnetic environment for the electrical supply network.

5.4.5.2 Under fault and circuit switching conditions in the **Distributor's** own **Distribution System** or in other interconnected **Systems** including the **Transmission System**, the voltage may fall and rise momentarily. The fall and rise in voltage will be affected by the type and location of faults, and earthing of the neutral points of the **Distributor's Distribution System, Transmission System and User's System**. Short duration voltage variations may also arise due to switching on the **Distribution System**, including the use of auto-reclosing, which gives rise to temporary interruptions. Short duration voltage variations may also arise due to the switching of **User** loads and from the operation of **User Equipment**.

5.4.5.3 The electromagnetic environment of the **Distribution System** is described in Malaysian Standards MS 1760 based on (IEC 61000-2-8), MS IEC 61000-2-2, MS IEC 61000-2-4 and MS IEC 61000-2-12 which describe the voltage characteristics (short duration voltage variations & steady state voltage disturbances) commonly experienced on **Distribution Systems** over a period of time.

5.4.5.4 In line with MS 1760: 2004, the **Distributor** shall make available, upon the request of **Users** appropriate information at any monitored point in the network on the magnitude, duration and number of short duration voltage variations for any given period of time.

5.4.6 **Power Quality and Disturbing Loads**

5.4.6.1 Certain types of **User Equipment** connected to the **Distributor's Distribution System** may give rise to voltage fluctuations and/or distortion which result in disturbance to other **Users** or damage to the **Distribution System** or connected **User Equipment**. Voltage variations include voltage step changes due to switching of **User** or **Distributor Demand** or **Equipment**, voltage flicker due to the operation of **User Equipment** such as welding machines and arc furnaces, **Voltage Unbalance** due to unbalanced loads and harmonic distortion of voltage.

5.4.6.2 The **Distributor** shall plan the **Distribution System** to maintain voltage harmonic distortion and voltage variations within the planning limits specified in the **Licence Standards** agreed with the **Commission** or, where no such standards are required to be agreed with the **Commission**, in accordance with Malaysian Standards (MS) or **IEC Standards** (IEC 61000 series) or other appropriate standards.

5.4.6.3 The applicable standards for voltage variations are **IEC Standards** 61000-3-7 for the **MV Distribution System** and **MS IEC 61000-3-3**, **MS IEC 61000-3-5** and **MS IEC 61000-3-11** for the **LV Distribution System**.

5.4.6.4 The applicable standards for harmonic voltages distortion are Standards 61000-3-6 for the **MV Distribution System** and **MS IEC 61000-3-2**, **IEC 61000-3-4** and **MS IEC 61000-3-12** for the **LV Distribution System**.

5.4.6.5 **Voltage Unbalance** electromagnetic compatibility levels are based on **IEC Standards** (61000 series) but planning limits are not covered in **IEC standards**. In this **Distribution Code** planning limits for **Voltage Unbalance** are based on United Kingdom Energy Networks Association Engineering Recommendation P29.

5.4.6.6 The limits specified in these standards are given below:

(a) Voltage Step Change

Table 5.1: Voltage limits on switching of load

Load Starting/Switching	Limit of Voltage Change
Starting/switching once or twice a year	8%
Infrequent single starting/switching or disconnection of Load – once in two hours or more hours, including capacitor or reactor banks	5%
Frequent starting/switching and/or disconnection of Load (e.g., Many times in a day)	3%

(b) Voltage Flicker

Table 5.2: Maximum allowable flicker severity

Distribution System and Transmission System Voltage Level at which the Fluctuating Load is Connected	Absolute Short Term Flicker Severity (Pst)	Absolute Long Term Flicker Severity (Plt)
Voltage Level >35 kV	0.8	0.6
Voltage Level <35 kV	0.9	0.7

Note: The terms (**Pst**) and (**Plt**) are defined in the **Licence Standard** and IEC Standards 61000-3-7

(c) Voltage Unbalance

- i) The maximum negative phase sequence component of the phase voltage on the **Distribution System (Voltage Unbalance)** shall remain below 1% unless abnormal conditions prevail.

- ii) Infrequent short duration peaks with a maximum value of 2% are permitted for **Voltage Unbalance**, subject to the prior agreement of the **Distributor** under the **Connection Agreement**. The **Distributor** will only agree following a specific assessment of the impact of these levels on the **Distributor's** other **Users' Equipment**.
- iii) At the terminals of a **User's** installation the unbalance voltage shall not exceed 1% for 5 occasions within any 30-minute time period.

(d) Harmonics

The maximum total levels of Harmonic Distortion at any **Connection Point** on the **Distribution System** from all sources under both planned outage and unplanned outage conditions, unless abnormal conditions prevail, shall not exceed:

- i) at 33kV, and 11kV: a Total Harmonic Distortion of 6.5%
- ii) at 400V and below, a Total Harmonic Distortion of 5%

The limits for individual components of harmonic voltage distortion are given in the **Licence Standards** and the **IEC** Standard 61000-3-6 at **MV** and **IEC** Standard 61000-3-4, MS **IEC** Standard 61000-3-2 and MS **IEC** Standard 61000-3-12 at **LV**.

5.4.6.7 When selecting **Equipment** and planning and operating the **User's System**, the **User** shall take account the level of distortion of voltage which may occur on the **Distribution System** in respect of voltage step changes, voltage flicker, **Voltage Unbalance** and harmonic content as set out in provision 5.4.6.6 of the **DPC**.

- (a) New Users shall indicate the distortion and flicker that the loads could generate by performing a complete system study based on a given '**Weak System Condition**' (minimum fault level). The full report of the study shall be submitted to the **Distributors** for approval at the stage of supply application.
- (b) If the all studies indicate the harmonic and flicker planning limits are violated, the customer shall install suitable compensator/filter (up to 100% compensation) to reduce the overall distortion and flicker below the allowable limits.

5.4.6.8 Where a **User's Equipment** causes voltage variations, **Voltage Unbalance**, or

harmonic voltage distortion to exceed the limits set out in provision 5.4.6.6 of the **DPC**, so as to persistently cause interference with the electricity supply to other **Users**, then the **Distributor** may discontinue electricity supply to that **User** until the situation is resolved and supply can be continued without causing interference with the electricity supply to other **Users**.

5.4.6.9 Current Harmonics

Total Harmonic Distortion Current Distortion (THD) shall be <5 % at inverter rated output. The point of measurement is at the combiner box of the inverters.

Each individual harmonic shall be limited to the percentages listed in table below (Current distortion limits reference to IEC 61727-2003 Table 1). Even harmonics in these ranges shall be less than 25 % of the lower odd harmonic limits listed.

Odd harmonics	Distortion limit (%)
3 – 9	< 4.0
11 – 15	< 2.0
17 – 21	< 1.5
23 – 33	< 0.6
Even harmonics	Distortion limit (%)
2 – 8	< 1.0
10 – 32	< 0.5

5.4.7 Superimposed Signals

5.4.7.1 Where a **User** intends to install mains borne signaling **Equipment** which may superimpose signals on the **LV Distribution System**, the **User's Equipment** shall comply with **IEC** standard 61000-3-8 as amended from time to time. Where a **User** proposes to use such **Equipment** to superimpose signals on the **LV Distribution System**, the prior agreement of the **Distributor** is required.

5.4.8 Transient Over voltages

5.4.8.1 Typical Basic Impulse Insulation Levels (BIL) of the **Distribution System** are as given in the following table 5.3. The **Customer's Plant and Apparatus** shall be compatible with the insulation levels of the **Distribution System**. The **Distributor** shall inform the **User** on request, the Basic Insulation Level of the **Distribution System**.

Table 5.3: Basic insulation level (BIL)

System Voltage (kV)	BIL (kV)
33	170
11	75

5.4.9 Short Circuit Levels

5.4.9.1 The **Distribution System** shall be planned such that the maximum sub-transient three phase symmetrical short circuit fault levels are not greater than 90% of the design short circuit break and make capacity of switchgear connected to the **Distribution System** and within 90% of the short time current rating of **Equipment** connected to the **Distribution System**.

5.4.9.2 Short circuit levels shall be calculated in accordance with **IEC 60909** and take account of the contribution of generating units and motors to short circuit level.

5.4.9.3 The **User** shall ensure that the short circuit rating of the equipment to be connected to the **Distributor's Distribution System** is not less than the design fault level at the point of connection.

5.4.9.4 The **Distributor** shall upon the request of the **User** provide details of the design short circuit level and the actual prospective maximum and minimum short circuit levels and the corresponding X/R ratio at the **Connection Point** and any future changes envisaged.

5.4.9.5 The DG shall upon the request of the Distributor provide details of the design short circuit level and the actual prospective maximum.

5.4.9.6 DG shall minimise its fault current contribution on reasonable request from Distributor.

5.5 Technical Standards and Specification of Equipment

5.5.1 **Plant and Apparatus** to be connected to the **Distribution System** and at the **User** interface is required to meet and conform to relevant technical standards and be compatible with the parameters (voltage, frequency, current rating and short circuit current rating and insulation level) of the **Distribution System**. These relevant technical standards shall include:

- (a) Malaysian National Standards (MS);
- (b) International, European technical standards, such as **IEC**, ISO, IEEE and EN standards; and
- (c) Other national standards such as BS, ANSI, DIN and ASA.
- (d) Licence Standards.
- (e) The **Distributor's** own standards and specifications.

5.5.2 The **User** shall ensure that the specification of **Plant and Apparatus** at the **Connection Point** shall be such as to permit operation within the applicable safety procedures agreed between the **Distributor** and the **User**.

5.5.3 Energy storages to be connected to the Distribution System and at the User interface is required to meet and conform to IEEE 1547 and IEC 62116 technical standards and be compatible with the parameters (voltage, frequency, current rating and short circuit current rating and insulation level) of the Distribution System.

5.6 Earthing

5.6.1 Earthing of the **User's** installation shall be in accordance with the **Electricity Supply Laws** and compatible with the earthing arrangements on the **Distribution System**.

5.6.2 The method of earthing, whether it is connected solidly to earth or through impedance, shall be compatible with the earthing arrangements with the Distributor's Distribution System. The specification of associated Equipment shall meet the voltages which will be imposed on the Equipment as a result of the method of earthing.

- 5.6.3 Users shall take precautions to limit the occurrence and effects of circuiting currents in respect of the neutral points of any interconnected system where there is more than one source of energy.

The **Distributor** shall provide details of the **Distribution System** earthing arrangements to the **User** on reasonable request of the **User**.

5.7 Protection and Control

5.7.1 General

- 5.7.1.1 **Protection** requirements vary widely depending on practices and needs of the particular **Distribution System**. In all cases, the basic requirement is that the **Users** arrangements for **Protection** at the **Connection Point**, including types of equipment and **Protection** settings, shall be compatible with standard practices on the **Distributor's Distribution System**, and be as the **Distributor** agrees during the application for connection process.

- 5.7.1.2 In order to provide for a circuit breaker, or **Equipment** having a similar function, failing to operate correctly to interrupt fault current on a **User MV System**, back-up **Protection** by operation of other circuit breakers or **Equipment** having a similar function shall normally be provided. The **Distributor** will advise the **User** if back up **Protection** is not required.

5.7.2 Specific Protection Requirements

- 5.7.2.1 **Users** shall take into consideration the following specific **Protection** practices of the **Distributor** to ensure that their installation has sufficient electromagnetic compatibility with the **Distribution System**.

- (a) Maximum clearance times (from fault current inception to fault clearing) shall be within the limits established by the **Distributor**.
- (b) Auto-reclosing or sequential switching features may be used on the **Distributor's Distribution System**. The **Distributor** will provide details on the operating sequence utilized for the supplies on the proposed installation so that the **User** can plan for this in the design and **Protection** of his facility.

- (c) On some **Distribution Systems**, e.g., lateral feeders or tee-offs, certain types of faults may cause disconnection of one phase only of a three-phase supply.
- (d) Disconnection time for DG during an event of loss of main shall be set as required by the Distributor.
- (e) Reconnection of the DG after Distribution System has recovered from an outage shall be set according to the requirement by the Distributor.

5.7.2.2 The **Distributor** shall provide details of the **Distribution System Protection** and control arrangements to a **User** on the reasonable request of the **User**.

5.7.2.3 The DG shall provide details of the System Protection and control arrangements to a Distributor on the reasonable request of the Distributor.

5.8 **Distributed Generation Planning and Design**

5.8.1 **Distributed Generation** planning, and design requirements vary widely depending on the practices and needs of the **Distribution System**. In all cases, the basic requirement is that the generation shall be compatible with planning and criteria specified in Section 5.4 of the **DPC** and the operation criteria specified in section 6.5 of the **DOC** and the standard practices on the **Distributor's Distribution System** and **Embedded Distributor's Distribution System**.

5.8.2 Guidance is provided on the planning and design of **Distributed Generation** connections for Sabah, with reference to Section 10.5. The particular technical requirements for connection will be as agreed by the **Distributor** as set out in section 7.8 of the **DCC**.

5.8.3 The principles for connection of **Distributed Generators** for different classes of generation, based on size, is set out below:

- (a) **Distributed Generation** with a total output at a **Connection Point** of 30 MW or more is required to comply with the both the **Distribution Code** and **Grid Code**. This class of generation may be subject to **Central Dispatch** and may be required to contribute to the stability of the **Total System** with technical requirements accordingly. These requirements are not repeated in the **Distribution Code** but may include a requirement to ride through faults, contribute to system response, and provide **Reactive Power** and **Black Start** facilities etc. as provided in the Grid Code.
- (b) **Distributed Generation** with a total output at a **Connection Point** of less than 30 MW at a **Connection Point** will normally be required to disconnect from the **Distribution System** in the event of the loss of the incoming supply from the **Distribution System** and other system abnormalities, so as to avoid unintended islanded operation or in the event of non-loss of incoming supply, the Distributor may require ride-through capability from the DG for voltage and frequency abnormalities.

(Table 5.4: Compliance requirement for Distributed Generation in and Sabah)

Connection Capacity (MW)	Distribution	Transmission
Sabah		
<5	Sabah Distribution Code	-
5-15	a) Sabah Distribution Code b) Subject to central dispatch and scheduling as in SGC	Sabah Grid Code
>15	Sabah Distribution Code Sabah Grid Code	Sabah Grid Code

5.9 Distribution System Planning

5.9.1 **Distributors and Embedded Distributors** shall prepare **Distribution System Plans of their Distribution System** by applying the best engineering practices in a **Distribution System Plan**, and shall be reviewed and updated in an annual **Distribution System Planning Review**.

(a) Distribution System Plan

The **Distributor** shall carry out planning studies to derive a **Distribution System Plan** for developing a target network for the next 5 years for the 33 kV **Distribution System** and for the next 3 years for the 11 kV **Distribution System**. The **Distribution System Plan** shall include the following items:

- i) **Demand** forecast;
- ii) target network;
- iii) existing and planned distribution network development including the requirements for equipment replacement and technology upgradation;
- iv) staged development from the first year to the fifth year including network replacement, strengthening and expansion taking into account the power flows, proposed power quality, circuit capacities, loadings, short-circuit levels, protection requirements, security of supply, power requirements etc;
- v) summary of network replacement, strengthening and expansion and the associated costs;
- vi) target performance;
- vii) any other relevant plans for improving the network performance;

The **Distributor's Distribution System Plan(s)** shall be sent to the **Commission** for information and review to provide inputs for future **Distributor's Distribution System Plans**.

(b) Distribution System Planning Review

The **Distributor** shall perform a rolling annual **Distribution System Planning Review** covering a 5-year period based on the **Distribution System Plan** taking into account changes in the load forecast and performance diagnosis. This review shall include all the items as per the Section 5.9.1(a).

(c) **Embedded Distribution System Plan**

The **Embedded Distributor** shall carry out the planning studies similar to the Distributors as per the Section 5.9.1(a). It shall be sent to the **Commission**, and the **Commission** may review and approve the Embedded Distribution System Plan, if it considers necessary.

(d) **Embedded Distribution System Planning Review**

The **Embedded Distributor** shall perform a rolling annual **Distribution System Planning Review** covering a 5-year period based on the **Embedded Distribution System Plan** taking into account changes in the load forecast and performance diagnosis. This review shall include all the items as per the Section 5.9.1(b). It shall be sent to the **Commission**, and the **Commission** may review and approve the Embedded Distribution System Plan, if it considers necessary.

5.10 Demand Forecasts

5.10.1 General

5.10.1.1 The **Distributor** is required by provision PC5.1 of the **Grid Code** to prepare **Demand** forecasts of the **Distributor's Area of Supply** according to the timescales, methods and procedures referred to in the **Grid Code**.

5.10.1.2 The required **Demand** forecasts cover the following planning horizons;

- (a) Short-term – one to two years
- (b) Medium-term – two to five years
- (c) Long-term – six to ten years

5.10.1.3 **Demand** forecasts are provided for each of the bulk supply transmission substations connected to the **Distributor's Distribution System** in a format specified in the **Grid Code**. Form 5A of Schedule 5 of the **Data Registration Code** specifies the detailed **Demand** forecast information to be submitted by the **Distributor** to the Grid Owner.

5.10.1.4 In order for the **Distributor** to prepare **Demand** forecasts, the following **Users** connected to the **Distributor's Distribution System** may be requested by the **Distributor** to submit **Demand** forecasts to the **Distributor** and shall submit the **Demand Forecasts** requested in the timescale requested:

- (a) **Consumers** with a **Peak Demand** of 3 MW for Sabah or more.
- (b) **Embedded Distributors.**
- (c) **Distributed Generators** with generating plant capacity **1 MW** or more.

5.10.2 Consumers Demand Forecast

5.10.2.1 **Consumers** with **Peak Demand** of 3MW for Sabah or more shall on the request of the **Distributor** submit annually the following **Demand** forecast to the **Distributor** in the timescale requested:

- (a) forecast of a typical weekly **Demand** profile in MW and MVA_r, in half-hourly intervals for the next financial year of the **Distributor**;
- (b) monthly energy consumption in MWh and the corresponding monthly **Peak Demand** in MW and MVA_r for the **Distributor's** next financial year; and
- (c) an annual load forecast in MW and MVA_r for the next five financial years.

5.10.2.2 Form 5B of Schedule 5 of the **Data Registration Code** specifies the detailed **Demand** forecast information to be submitted by a **Consumer** to the **Distributor**.

5.10.3 Embedded Distributors Demand Forecast

5.10.3.1 Embedded Distributors connected to the Distributor's Distribution System shall on request of the Distributor submit annually the following Demand forecasts to the Distributor in the timescale requested:

- (a) forecast of typical weekly import and/or export **Demand** profile in MW and MVA_r, in half-hourly intervals for the next financial year of the **Distributor**;
- (b) monthly energy import and/or export in MWh and the corresponding monthly **Peak Demand** export and/or import in MW and MVA_r for the **Distributor's** next financial year; and
- (c) annual import and/or export **Demand** forecast in MW and MVA_r for the next five financial years.

5.10.3.2 Form 5C of Schedule 5 of the **Data Registration Code** specifies the detailed **Demand** forecast information to be submitted by an **Embedded Distributor** to the **Distributor**.

5.10.4 **Distributed Generators Generating Plant Output Forecast**

5.10.4.1 **Distributed Generators** with generating plant capacity exceeding 1 MW shall on request of the **Distributor** submit annually the following generating output forecasts to the **Distributor** in the timescale requested:

- (a) forecast of a typical weekly **Demand** profile in MW and MVA_r, in half-hourly interval for the next financial year of the **Distributor**;
- (b) forecast of the generation maximum MW and MVA_r output into the **Distribution System** for the next five financial years

5.10.4.2 Form 5D of Schedule 5 of the **Data Registration Code** specifies the detailed **Demand** forecast information to be submitted by a **Distributed Generator** to the **Distributor**.

5.10.5 **Factors to be considered for Demand Forecasts**

5.10.5.1 In determining Demand forecasts, Distributors and Users will take into consideration the following relevant factors:

- (a) category of **Consumers** and energy use intensity;
- (b) economic growth factors;
- (c) state and local authorities land use zoning;
- (d) types of commercial activities;
- (e) historical energy and **Demand** trends;
- (f) Distributed Generator's output and export;
- (g) DG de-rating or degradation;
- (h) any other necessary factors reasonably considered

5.11 **Information to Users**

5.11.1 **Load Profiles and Characteristics at Connection Points**

5.11.1.1 For the purpose of planning a connection to the **Distributor's Distribution System**, **Users** may require information related to load profiles and power quality characteristics. The **Distributor** shall make available such information upon the reasonable request of a **User** connected to the **Distribution System** or any **User** who intends to connect to the **Distributor's Distribution System**. In order to provide this information, the **Distributor** shall maintain records of Load Profiles and Power Quality Characteristics as specified in Sections 5.11.2 and 5.11.3 of the **DPC**.

5.11.2 Load Profiles

5.11.2.1 The **Distributor** shall maintain records of load profiles and characteristics at the points of interface, namely transmission bulk supply substations, **Distributed Generators**, and interconnection with **Embedded Distributors**. The load profiles shall be recorded at the following points on the last Wednesday of each month:

- (a) all incoming feeders at the interface with the transmission grid, distributed generation incoming feeders, and points of interconnection with **Embedded Distributors**; and
- (b) all outgoing feeders to the **Distributor's Distribution System** from the bulk supply transmission substations.

5.11.2.2 The load readings in MW, MVA_r, MWh, MVA_rh and voltage in kV shall be recorded in a half-hourly interval for all incoming feeders in (a) above. For all outgoing feeders in (b), MW and MVA_r and/or current (A) readings in a half-hourly interval shall be recorded.

Form 5E of Schedule 5 of the **Data Registration Code** specifies the load profile data to be recorded by the **Distributor**, the required recording period and the parameters to be determined from the load profile.

5.11.3 Power Quality Characteristics

5.11.3.1 The **Distributor** shall keep the following records of power quality related supply characteristics at selected points on the **Distribution System**.

- (a) Voltage harmonic distortion level;
- (b) Incidents of voltage dips and swells; and
- (c) Incidents of voltage flicker.

5.11.3.2 Form 5F of Schedule 5 of the **Data Registration Code** specifies in detail the power quality related data to be recorded by the **Distributor**, the required recording period and the parameters to be determined from the recorded data.

Distribution Operating Code

6.1 Introduction

6.1.1 The **Distribution Operating Code (DOC)** contains requirements for operating the **Distributor's Distribution System** that cover supply performance requirements and coordination of **Operational Planning**, control and operation, reporting of outages and interruptions, monitoring of performance, and co-ordination of safety.

6.1.2 Operation of a **Distribution System** includes but is not limited to:

- (a) carrying out **Operational Planning**, maintenance and/or inspection scheduling, and switching operations plans;
- (b) performing voltage and/or power flow controls to ensure the **Distribution System** is operated within the supply performance requirements;
- (c) monitoring **Distribution System** performance through measurements and records to ensure compliance with the supply performance requirements;
- (d) reporting of **Distribution System** performance including outages and interruptions as required by the **Licence**;
- (e) performing switching operations to restore supply following network element outages or for **Equipment** maintenance or for diverting power flows; and
- (f) ensuring the safety of operating staff, contract personnel and the public according to the provisions of, the **Electricity Supply Laws** and **Licence**.

6.2 Scope

6.2.1 The **DOC** applies to all **Distributors, Consumers, Distributed Generators** and **Embedded Distributors** unless otherwise limited in application in each section of the **DOC**. All **Distributors** and **Users** connected to the **Distributor's Distribution System** shall comply with the requirements of the **DOC** and **Licence**.

6.3 Objectives

6.3.1 The objectives of the **Distribution Operating Codes (DOC)** are:

- (a) to ensure that the **Distributor's Distribution System** is operated to meet supply performance requirements in terms of adequacy, supply security, power quality, and safety for all **Users**;
- (b) to specify requirements for determining and submission of operational **Demand** forecasts by all **Users** connected to the **Distributor's Distribution System**;
- (c) to specify operating criteria and supply performance requirements to be complied with by all **Distributors** in **Distribution System** operation and **Operational Planning**;
- (d) to establish requirements for coordination of inspection and maintenance, **Distribution System** control, switching operations and monitoring of performance at the points of interface between the **Distributors** and **Users**; and
- (e) to establish guidelines for exchange of operating information between the **Distributors** and **Users**.

6.4 Distribution Operational Planning

6.4.1 Annual Operation Plan

6.4.1.1 A **Distribution System** operation plan contains strategies on how the **Distribution System** shall be operated under normal and abnormal situations following contingencies after taking into consideration items including but not limited to the following:

- (a) changes in **Demand Forecasts**;
- (b) changes in scheduled output of **Distributed Generators**;
- (c) changes in scheduled import/export from **Embedded Distributors**;
- (d) network reconfiguration and constraints;
- (e) implementation or deferment of reinforcement projects including commissioning of major substations;
- (f) implementation or deferment of new connections to **Users**
- (g) scheduled outages for maintenance and/or **Equipment** inspection;
- (h) scheduled outages to facilitate connection to the **Distribution System**;
and
- (i) non-scheduled outages.

- 6.4.1.2 The objective of each of the operating strategies established in the operation plan is to meet requirements of operation criteria specified in section 6.5 of the **DOC**. When establishing the operation plan, the **Distributor** shall employ the best engineering and prudent utility practices as far as reasonable. The **Distributor** shall also take account the obligations of the **Distributor** and **Users** to the **GSO** in respect of the **Operational Planning** requirements of the **Grid Code**.
- 6.4.1.3 It is required that the **Distributor** shall establish an **Annual Operation Plan** setting out the operating strategies, network configuration and **Distribution System** outages and relevant **User System** outages covering the **Distributor's** next financial year. The **Distributor** shall review this plan on a monthly basis to take account of the latest changes in operating scenarios.
- 6.4.1.4 For the purpose of preparing the **Annual Operation Plan**, the **Distributor** may require information from **Users** connected to the **Distributor's Distribution System**. When such information is required to be exchanged, the **Distributor** shall inform the **User** of the requirement and give a reasonable time period for notices of request and submission of the information.
- 6.4.1.5 Where the **Annual Operation Plan** requires actions by **Users** the **Distributor** will discuss and finalise with those **Users** in reasonable time the nature of the actions to be undertaken and when actions are to be implemented. **Users** are then obliged to implement the agreed actions on the instruction of the **Distributor**.

6.4.2 Operational Demand and Generation Forecasts

6.4.2.1 General

- 6.4.2.1.1 Provision 5.10.1.1 of the **Distribution Planning Code (DPC)** requires the **Distributor** to prepare **Demand** forecasts including a short-term forecast for **Operational Planning**. The **Distributor** will use these **Demand** forecasts to prepare the necessary **Annual Operation Plan**. Major changes in load consumption forecast or generation output forecast would require the **Distributor** to make adjustments to the **Annual Operation Plan**. Where a **User** has been requested to provide **Demand** forecasts under provision 5.10.2.1, 5.10.3.1, or 5.10.4.1 of the **DPC** the **User** shall be responsible for informing the **Distributor** of such changes, according to the 6.4.2.2, 6.4.2.3 or 6.4.2.4 of the **DOC**.

6.4.2.2 Major Changes in Consumer's Demand Forecast

6.4.2.2.1 **Consumers** with **Peak Demand** of 3 MW for Sabah or more shall inform the **Distributor** of the following changes to the load forecast submitted under provision 5.10.2.1 of the **DPC** one (1) month before the implementation of the changes:

- (a) scheduled weekly **Demand** profiles having a difference greater than 3MW from the typical weekly **Demand** profile submitted under provision 5.10.2.1(a) of the **DPC**, in half-hourly intervals; and
- (b) scheduled monthly **Peak Demand** in MW having a difference greater than 3 MW from the monthly **Peak Demand** forecast submitted under provision 5.10.2.1(b) of the **DPC**.

6.4.2.2.2 Form 6B of Schedule 6 of the **Data Registration Code** specifies the detailed information to be submitted by a **Consumer** to the **Distributor** to inform of the above change.

6.4.2.3 Major Changes in Embedded Distributor Demand Forecast

6.4.2.3.1 **Embedded Distributors** connected to the **Distributor's Distribution System** shall inform the **Distributor** of the following changes to the **Demand** forecast submitted under provision 5.10.3.1 of the **DPC** one (1) month before the implementation of the changes:

- (a) scheduled weekly import and/or export **Demand** profiles across the connection having difference greater than 1 MW for Sabah, from the typical weekly **Demand** submitted under provision 5.10.3.1(a) of the **DPC**, in half-hourly intervals; and
- (b) scheduled monthly **Peak Demand** export and/or import in MW having difference greater than 1 MW for Sabah, from the monthly **Peak Demand** forecast submitted under provision 5.10.3.1(b) of the **DPC**.

6.4.2.3.2 Form 6C of Schedule 6 of the **Data Registration Code** specifies the detailed information to be submitted by an **Embedded Distributor** to the **Distributor** to inform of the above change.

6.4.2.4 Major Changes in Distributed Generators Generation Output Forecast

6.4.2.4.1 **Distributed Generators** with generating plant capacity exceeding 1 MW shall inform the **Distributor** of any of the following changes to the **Demand**

forecast submitted under provision 5.10.4.1 of the **DPC** one (1) month before the implementation of the changes:

- (a) scheduled weekly output profiles of the generating plant having difference greater than 50% from the forecast of the typical weekly generation output submitted under provision 5.10.4.1(a) of the **DPC** in half-hourly interval; and
- (b) scheduled monthly generation maximum and minimum output having difference greater than 50% from the **Distributor's** current financial year load forecast submitted under provision 5.10.4.1(b) of the **DPC**.

6.4.2.4.2 Form 6D of Schedule 6 of the **Data Registration Code** specifies the detailed information to be submitted by a **Distributed Generator** to the **Distributor** to inform of the above changes.

6.4.3 Annual Operating Data

6.4.3.1 General

6.4.3.1.1 **Users** so requested by the **Distributor** shall provide information on scheduled outages and switching operations detailed in provisions 6.4.3.2, 6.4.3.3 and 6.4.3.4 of this **DOC**.

6.4.3.2 Consumer's Operating Data

6.4.3.2.1 **Consumers** with a **Peak Demand** of 3MW for Sabah, or more upon the request of the **Distributor**, shall provide the following data and information before the start of the **Distributor's** next financial year:

- (a) scheduled outages of **Plant** and **Equipment** that will result in no or limited **Demand** taken from the **Distributor's Distribution System**; and
- (b) any switching operation to be carried out within the installation that will result in temporary disconnection and/or voltage variations at the point of interface with the **Distributor's Distribution System**.

6.4.3.2.2 Following the submission of the above information, the **Consumer** shall inform the **Distributor** of major changes to the implementation of items 6.4.3.2.1(a) and 6.4.3.2.1(b), if any, one (1) month before the implementation of the changes. Major changes constitute deferment, postponement, changes in duration, changes in operating sequence, and any other changes that in the opinion of the **Consumer** will have or may have an effect on the operation of the **Distributor's Distribution System**.

6.4.3.3 Embedded Distributor's Operating Data

6.4.3.3.1 **Embedded Distributors**, on request of the **Distributor** shall provide the following information before the start of the **Distributor's** next financial year:

- (a) scheduled outages of **Plant** and **Equipment** for the purpose of maintenance and/or inspection that will result in no or limited export to or import from the **Distributor's Distribution System**; and
- (b) any switching operation to be carried out within the **Embedded Distributor's Distribution System** that will result in temporary outage at the point of interface to the **Distributor's Distribution System**.

6.4.3.3.2 Following the submission of the above information, the **Embedded Distributor** shall inform the **Distributor** of major changes to the implementation of items 6.4.3.3.1(a) and 6.4.3.3.1 (b), if any, one (1) month before the implementation of the changes. Major changes constitute deferment, postponement, changes in duration, changes in operating sequence, and any other changes that in the opinion of the **Embedded Distributor** will have or may have an effect on the operation of the **Distributor's Distribution System**.

6.4.3.4 Distributed Generator's Operating Data

6.4.3.4.1 The **Distributed Generator**, on request of the **Distributor** shall provide the following information before the start of the **Distributor's** financial year:

- (a) scheduled outages of **Generating Units** and **Equipment** for the purposes of maintenance and/or inspection that will result in no generation output or limited generation output to the **Distributor's Distribution System**; and

- (b) any switching operation to be carried out within the **Distributed Generator's Plant** that will result in temporary disconnection and/or voltage variations at the point of interface to the **Distribution System**.

6.4.3.4.2 Following the submission of the above information the **Distributed Generator** shall inform the **Distributor** of major changes to the implementation of items 6.4.3.4.1(a) and 6.4.3.4.1 (b), if any, one (1) month before the implementation of the changes. Major changes constitute deferment, postponement, changes in duration, changes in operating sequence, and any other changes that in the opinion of the **Distributed Generator** will have or may have an effect on the operations of the **Distributor's Distribution System**.

6.5 Operation Criteria

6.5.0 General

6.5.0.1 The objective of this section of the **DOC** is to outline normal requirements to be complied with by all **Distributors** in maintaining network performance parameters when operating the **Distribution System** and to be taken into account in **Operational Planning**. These normal requirements do not prevent the **Distributor** from providing higher performance standard.

6.5.0.2 Each **Distributor** shall operate and maintain its **Distribution System** in accordance with the requirements not less than set out in this section using the best engineering and prudent utility practices as far as applicable. It is important to note that operating performance criteria are sets of requirements to be satisfied in day-to-day operation of the network and are consistent with the planning criteria specified in section 5.4 of the **DPC**.

6.5.1 Security of Supply

6.5.1.1 Supply security to **Users** connected to the **Distribution System** is concerned with the availability of supply following a circuit outage or supply interruption. Availability of supply in these circumstances depends on the security provided at the planning stage in accordance with the planning security standard specified in **DPC** 5.4.2 and appropriate agreements for security of connections to **Users**. Security of supply and restoration times following an outage are also dependent on **Protection** and control systems, sequence of switching operations, and availability of reserve capacity of the healthy parts of the network.

- 6.5.1.2 In anticipating the occurrences of supply interruptions following network element outages, the **Distributor**, when establishing the **Annual Operating Plan** and review thereof shall develop all the necessary contingency plans including switching operation sequences, network reconfiguration, provision of sufficient portable, backup or standby supplies to restore supplies according to the supply security requirements specified in **DPC 5.4.2**.
- 6.5.1.3 Where the **Distributor** has a separate agreement with a **User** for maintaining security of supply at agreed levels, the **Distributor** shall honour the requirements in accordance with the terms and conditions of such agreements.

6.5.2 Circuit Loading

- 6.5.2.1 Provision 5.4.2.3 (a) specifies that the **Distribution System** shall be planned so that the required security levels are achieved such that under normal operation of the **Distribution System**, and for any single circuit outage, the loading on the **Distribution System** shall be maintained within the continuous ratings of the **Distribution Equipment**. In operational timescales including **Operational Planning** the **Distributor** may consider loading the **Equipment**, lines and cables to their cyclic or emergency ratings in order to meet security requirements and to maintain supplies. Under such requirements the **Distributor** shall take into consideration the overload settings of the relevant **Protection** equipment.

6.5.3 Steady State Voltage Variations

- 6.5.3.1 **DPC 5.4.4** specifies the planning criteria for steady state voltage levels under normal conditions and contingency conditions and for the different classes of User. These steady state voltage levels shall also be complied with in operational timescales including **Operational Planning**.
- 6.5.3.2 Where the **Distributor** has a separate agreement with a **User** for maintaining steady state voltage variations, the **Distributor** shall honour the requirements in accordance with the terms and conditions of such agreements.

6.5.4 Short Duration Voltage Variations

- 6.5.4.1 Short duration supply voltage variations include voltage dips, voltage swells, momentary interruptions and temporary interruptions in supply and these events are part of the electromagnetic environment for the electrical supply network.
- 6.5.4.2 Under fault and circuit switching conditions in the **Distributors** own **Distribution System**, in the **Transmission System** and **User Systems**, the voltage may fall and rise momentarily. The short duration falls and rise in voltage will be affected by the type of faults, location of faults, and earthing of the neutral points of the **Transmission System**, **Distributor's System** and **User Systems**. Short duration voltage variations may also arise due to switching on the **Distribution System**, including the use of auto-reclosing, which gives rise to temporary interruptions. Short duration voltage variations may also arise due to the switching of User loads and from the operation of **User Equipment**.
- 6.5.4.3 The short duration voltage variations may result in mal-operation of voltage-sensitive Equipment connected to the system. Both Distributors and Users shall take adequate measures to ensure proper Electromagnetic Compatibility (EMC) is achieved between the Distribution System & Users' voltage-sensitive equipment.
- (a) The **Distributor** shall investigate complaints from **Users** on short duration voltage variations and make proposals to reduce the frequency, magnitude and duration of the voltage variations originating from the **Distributor's** own **Distribution System** to the level required as per the Distribution Code. In case, a User requires protection beyond the level specified in the Distribution Code, he shall install suitable protection devices designed to limit the variations to that required by his system.
 - (b) **Users** with voltage-sensitive loads or intending to connect voltage sensitive loads to the **Distribution System** shall take into account this short duration variation in voltage in planning their installation and selecting **Equipment** from appropriate specifications or standards to ensure sufficient intrinsic immunity to short duration voltage variations
 - (c) This initiative will ensure minimum deterioration of performance or lapse in operation of sensitive equipment due to short duration voltage variations.

6.5.4.4 Provision 5.4.5.4 requires the **Distributor** to provide information upon request of **Users** on the expected magnitude, duration and number of short duration voltage variations for any given period of time at any monitored point in the network. Such information shall be used by **Users** connected to the **Distribution System** to take operational measures to eliminate or minimize the impacts of the short duration voltage variations on the operation of their respective installation. However, it is recognized that the Electromagnetic Compatibility Standards for **Users Equipment** such as SEMI F47 may not be fully compatible with the types of voltage variations experienced on the **Distribution System**.

6.5.5 Requirements for Network Support from DG (Solar PV Type)

The DG shall provide support to the network to ensure that the system is stable. The DGs shall be equipped with the following features for network support:

6.5.5.1 Low Voltage Ride Through

6.5.5.1.1 During disturbance at transmission system, distribution system will experience temporary low voltage/sag. The LSS plant is expected to continuously operate during distribution system voltage fluctuation as shown

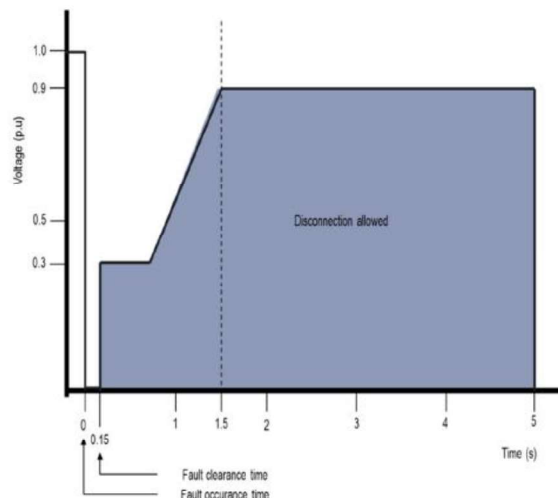

6.5.5.2 Frequency disturbance

6.5.5.2.1 The LSS plant is expected to be uninterrupted within the frequency range of 47Hz to 50.5Hz.

During frequency disturbance, when the frequency increases more than 50.5Hz, the LSS plant shall reduce its power output as shown.

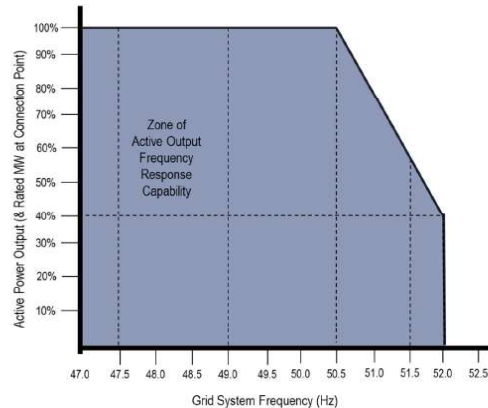

6.5.5.3 Power output management

6.5.5.3.1 The DG shall be able to reduce power output or disconnect from distribution system during system contingencies. The DG plant shall reduce its generation output to avoid voltage rise above the limit. The LSS plant shall monitor and ensure that power generation does not exceed the contracted capacity. Inverter shall have the capability to perform active/reactive power control for voltage regulation.

6.5.5.4 Droop curve

6.5.5.4.1 The DG shall be fitted with a droop controller or equivalent control device to provide Frequency response under normal operational conditions

6.5.5.5 Reactive power

6.5.5.5.1 The LSS plant shall be able to deliver the reactive power requirement at the connection point as shown in Figure 7. Full range of reactive power 0.85 lagging to 0.9 leading shall be achieved at 20% output.

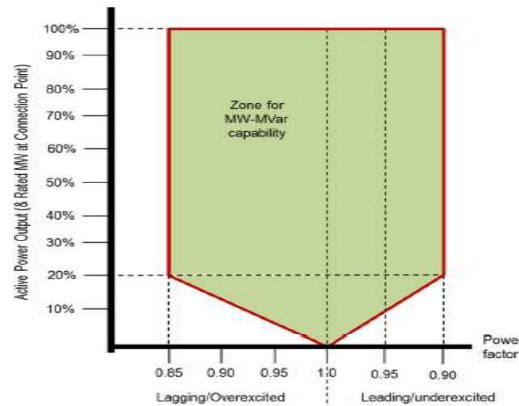

6.6 Monitoring and Testing of Performance

6.6.1 General

6.6.1.1 To ensure that the **Distribution System** is operated efficiently and within the requirements of the **Electricity Supply Laws** the **Licence** and the **Distribution Code**, the **Distributor**, the **Medium Voltage Embedded Distributor**, the **Medium Voltage Distributed Generator** and the **medium voltage user are** required to carry out monitoring and/or testing to confirm that the technical performance is within the limits specified in the **Distribution Code**. This section specifies the required monitoring and/or tests.

6.6.2 Steady-state Voltage Limits

6.6.2.1 The **Distributor**, the **Medium Voltage Embedded Distributor**, the **Medium Voltage Distributed Generator** and the **medium voltage users** shall maintain records of steady-state voltage performance at selected points of the system including but not limited to the following:

- (a) all bulk transmission substations;
- (b) representative 33 kV substations; and
- (c) all interface points with **Embedded Distributors** and **Distributed Generators** and **Consumers** connected to the **Medium Voltage Distribution System**.

- 6.6.2.2 The **Distributor** will determine the required frequency of tests and shall test voltage performance during peak and light load periods of the **Distribution System**. The **Distributor** will also carry out necessary testing and/or monitoring on receipt of any voltage related complaint and/or request for specific voltage testing and/or monitoring from a **User**. Where testing and/or monitoring is required at the point of interfaces with **Users**, the **Distributor** will advise the **User** of the requirement and will make the results of such tests available to the **User**.
- 6.6.2.3 Where the results of the above tests show that the steady state voltage is outside the required limits, the **Distributor** shall where possible immediately rectify the situation if the voltage setting is within the control of the **Distributor**. If the voltage setting is within the control of a **User**, the **Distributor** will advise the **User** and the **User** shall where possible immediately take the necessary actions to adjust the voltage within the required limits. Where the voltage outside limits cannot be remedied immediately by adjustment of a voltage setting then the **Distributor** and /or **User** will implement measures to remedy the situation in a time frame mutually acceptable to affected parties.
- 6.6.3 **Power Quality Related Monitoring**
- 6.6.3.1 Section 5.11.3 of the **DPC** specifies the requirements for the **Distributor** to maintain power quality records related to harmonics and voltage dips and swells. The **Distributor** shall maintain these power quality records for selected points at the interface with **Transmission System**, **Distributed Generators** and **Embedded Distributors** connected to the **Distribution System at Medium Voltage**.
- 6.6.3.2 The **Distributor** will determine the reasonable frequency of tests for monitoring of harmonic distortion levels, which shall measure performance during peak and light load periods of the **Distribution System**. Voltage dips and swells shall be monitored continuously.
- 6.6.3.3 The **Distributor** will also carry out necessary testing and/or monitoring on receipt of any complaint on or related to power quality and/or a request for specific power quality testing and /or monitoring. Where testing and/or monitoring is required at the point of interfaces with the **User** the **Distributor** will advise the **User** of the requirement and will make the results of such tests available to the **User**.

6.6.3.4 Where the results of the above tests show that the power quality parameter is outside the limits specified in DPC 5.4.6.6, the **Distributor** shall rectify the situation as soon as is reasonably practicable if it is within the control of the **Distributor**. Where the power quality parameter outside limits is due to the characteristics of a **User's** connected load the **Distributor** will advise the **User** and the **Distributor** and **User** shall discuss and finalise the necessary actions to be taken by the **User** to rectify the situation. In case of disagreement, the matter shall be referred to **Commission** whose decision shall be final.

6.6.4 **Obligations of Users to Monitor and/or Test Performance**

6.6.4.1 **Consumers, Embedded Distributors and Distributed Generators**, on the request of the **Distributor** shall carry out monitoring and or testing of steady-state voltage and power quality performance on their side of the interface according to the requirements specified by the **Distributor**. This request may be made by the Distributor when he finds that electrical fluctuations in the Distribution System are more than that specified in the Distribution Code.

6.7 **Safety Requirements**

6.7.0 **General**

6.7.0.1 The objectives of this section are:

- (a) Establish the requirements on the **Distributor** and the **Users** to carry out work and/or testing on the **Distribution System** or **User System** respectively meeting the requirements of the **Electricity Supply Law** and **Safety Rules** of the **Distributor** and **Users**; and
- (b) Ensure safe work conditions for personnel working on or in close proximity to **Plant** and **Apparatus** on the **Distribution System** or personnel who may have to work at or use the equipment at the interface between the **Distribution System** and a **User System**.

6.7.1 Operational Responsibilities

6.7.1.1 On sites which contain both **Distributor-owned Equipment** and **User-owned Equipment** which operate at **Medium Voltage**, the **Distributor** and **User** shall record the respective ownership of **Equipment** in a written agreement between the **Distributor** and **User** together with the responsibilities for control, operation and maintenance of the respective **Equipment**. In the absence of a separate agreement between the parties stating otherwise, construction, commissioning, control, operation and maintenance responsibilities shall follow ownership.

6.7.1.2 On sites which contain both **Distributor-owned Equipment** and **User-owned Equipment** which operates at **Medium Voltage** the **Distributor** and **User** shall coordinate the naming and numbering of **Equipment** to ensure that there is no duplication or conflict in the naming and numbering of **Equipment** at the interface of the **Distributor** and **User**.

6.7.2 Safety Coordination

6.7.2.1 This section of the **DOC** specifies requirements for the **Distributor, Consumers, Embedded Distributors** and **Distributed Generators** to coordinate, establish and maintain the necessary isolation and earthing when work and/or tests are to be carried out in the **Distributor's Distribution System** or in the **System** of a **User** connected to the **Medium Voltage Distribution System**. The safety coordination described in this section applies when work and/or tests are to be carried out involving the interface between the **Distributor** and the **User** and does not absolve the **Distributor** and **User** from meeting the requirements of the **Electricity Supply Laws**, individual **Licence** conditions, safety rules of the **Distributor** and of the **User** and the **Distribution Code**.

6.7.2.2 The safety coordination procedures to be adopted by the **Distributor** and **Users** for work or testing at the interface between the **Distributor** and the **User** shall include the following prerequisites:

- (a) at each **Connection Point** between the **Distributor** and **User**, the boundary of ownership and operational responsibilities is clearly defined as specified in provision 6.7.1.1;
- (b) the **Distributor** and the **User** shall provide each other with the operating diagrams of their respective side of the **Connection Point**;

- (c) the names of persons responsible for operation on the **Distributor's** and **User's Systems**; and
- (d) the **Distributor** and the **User** shall exchange information on safety rules **and/or** safety instructions as practiced in their respective **Systems**.

6.7.2.3 All switching and other operations shall be carried out according to the procedures as defined in the **Distributor's** Safety Rules, which shall include but is not limited to

- (i) Coordination
- (ii) Isolation
- (iii) Earthing
- (iv) Recording
- (v) Testing
- (vi) Commissioning
- (vii) Documentation
- (viii) Re-energizing

6.7.2.4 The safety requirements to be adopted by the DG and DL for work or testing at the interconnection facilities shall include the following:

- a) The DG shall provide the single line diagrams of the interconnection facilities at the respective side of the connection point;
- b) The DG shall have their own safety rules and/or safety instructions which comply with the Electricity Supply Enactment 2024 and prudent utility practices.
- c) The DG shall designate competent personnel registered with **Commission** to operate the interconnection facilities within their boundary.

6.7.3 Competency of Persons

6.7.3.1 The **Distributor** and **Users** are required to maintain adequate staff properly trained for the administration, operation and maintenance of the **Distribution System** and **Users' Systems** and shall meet the competency requirements of the **Electricity Supply Laws**.

6.7.4 Reporting of Accidents

6.7.4.1 Part VII of the **Enactment** specifies the requirements for notification, for investigation by the **Commission**, of a serious accident resulting in loss of life

or injury to any person or serious damage to property. In these cases, no alteration or addition shall be made to the installation without the approval of the **Commission**. In cases of less serious damage to **Equipment** or property or where incidents are due to animals, birds, trees or other vegetation, the **Distributor** may, in order to expedite restoration of service to **Consumers**, proceed to restore the facility to a safe and working state, prior to any investigation and site visit by the **Commission**, providing that all required documentation has been provided to the **Commission**.

6.8 Operational Requirements

6.8.1 Distribution System Control Structure

6.8.1.1 The structure and organization of **Distribution System** operation may vary from one **Distributor** to another but generally consists of **Control Centres** and/or **Customer Management Centres**.

6.8.1.2 The **Control Centres** monitor, control and operate parts of the **Distributor's Distribution System** using a team of operators on a 24-hour basis and have direct communication with **Users** and the **GSO**, where applicable. All communications with **Distributed Generators** and **Embedded Distributors** are handled by the **Control Centre** and **Consumers** are handled by the **Customer Management Centre**. **Control Centres** deal with operation of the **Medium Voltage Distribution System**. **Users** requiring access to the **Control Centre** will be provided with appropriate telephone numbers. **Customer Management Centres** provide an enquiry service and central location for reporting loss of supply and other incidents on the **Distribution System** via published telephone numbers.

6.8.1.3 The Distribution System control structure shall incorporate the facilities for active control of the DG. The provision of SCADA together with RTU cubicle, associated cards and SCADA ready switchgear is mandatory for all DG plant interconnection of 1 MW and above. SCADA equipment to be used is subject to the approval by Distributor

The following parameters are to be made available for monitoring by the SDCC.

- a) Frequency (Hz)
- b) Voltage (V)
- c) Current (A)

- d) Real Power Energy flow (kW or MW)
- e) Reactive Power Energy flow (kVAR or MVar)
- f) Energy meters
- g) Circuit Breaker status
- h) Relay indications

All interfacing wirings are to be prepared by DG developer with Distributor supervision.

6.8.2 Operational Liaison Arrangements

6.8.2.1 General

- 6.8.2.1.1 To co-ordinate the operation of the **Medium Voltage Distribution System**, the **Distributor** and **Users** connected to the **Medium Voltage Distribution System** shall maintain communications and exchange information on **Operations** and/or **Events** on the **Distribution System** or the **Systems** of **Users** which have had or may have had, or will have or may have an effect on the **Distributor's Distribution System** or the **System** of any **User** as required in this section of the **DOC**. Upon receipt of the notification, each party involved will make appropriate assessment of the **operations** and/or **Events** and take appropriate actions to minimize or eliminate any adverse effects of such **Operations** and/or **Events** on **Users**.

6.8.2.2 Notification of Operations

- 6.8.2.1.1 **Distributed Generators, Consumers and Embedded Distributors** connected to the **Medium Voltage Distribution System** are required to notify the **Distributor** of any **Operation** that will have or may have an effect on the **MV Distribution System** including but not limited to the following:
- (a) implementation of scheduled outages of **Plant** and/or **Equipment** which has been reported and arranged in accordance with provisions in Section 6.4 of the **DOC**;
 - (b) switching operations that will result in temporary disconnection at the point of interface to the **Distributor's MV Distribution System**;
 - (c) switching operations for paralleling of **Systems**;
 - (d) **Generating Unit** synchronizing; and
 - (e) operations with implications for voltage control.

- 6.8.2.1.2 The notification to the **Distributor** shall contain sufficient detail describing the operations and locations of **Equipment** and shall be provided before the implementation of the operations in a reasonable time period to allow the **Distributor** to make the necessary assessment of the implications of the operations.
- 6.8.2.1.3 In case of any operation in the **MV Distribution System** or any receipt of notification of operation in the **Transmission System** or any receipt of notification of operation in the **Systems of Users**, which in the opinion of the **Distributor** will have or may have effects on **Systems** of other connected **Users**, the **Distributor** will inform the other **Users** of such operations in a reasonable time to allow the other **Users** to make assessment of the implications of the operations and/or take necessary action to minimize or eliminate any adverse impacts of the operation on the other **Users'** installation, **Plant** and **Equipment**.

6.8.2.3 Notification of Events

- 6.8.2.3.1 **Distributed Generators, Consumers and Embedded Distributors** connected to the **Medium Voltage Distribution System** are required to notify the **Distributor** of any **Event** in their **System** which has had or may have had an effect on the **MV Distribution System** including but not limited to the following:
- (a) the activation of any alarm or indication of any abnormal operating conditions;
 - (b) breakdown of or faults on, forced or partial outages of **Plant** and/or **Apparatus** including **Protection** and controls;
 - (c) increased risk of inadvertent **Protection** operation;
 - (d) operation of **Plant** and/or **Apparatus** either manually or automatically; and
 - (e) occurrence of voltage levels outside the required limits;
- 6.8.2.3.2 The notification to the **Distributor** shall be given in sufficient detail to describe the **Event** and locations of **Equipment** immediately by phone after the **Event** has occurred to allow for the **Distributor** to make the necessary assessment on the implications of the **Event** and if necessary to make adjustment to the **Distribution System**.

6.8.2.3.3 In case of any **Event** that has occurred in the **MV Distribution System** or any receipt of notification of an **Event** in the **Transmission System** or any receipt of notification of **Event** in the **System** of **Users**, which in the opinion of the **Distributor**, has had or may have had effects on **System** of other connected **Users**, the **Distributor** will inform the other **Users** of such **Event** in a reasonable time after the occurrence of the event to allow for the other **Users** to make assessment of the implications of the **Event** and/or take necessary action to minimize or eliminate any adverse impacts of the **Event** on the other **Users'** installation, **Plant** and **Equipment**.

6.8.2.4 Reporting of Significant Incidents by Users

6.8.2.4.1 In order for the **Distributor** to record and make reports of **Significant Incidents** within the electrical installations of **Users** or points of interface between **Users** and the **MV Distribution System** which affect the **MV Distribution System**, **Transmission System** or **Systems** of other **Users**, then in addition to the notification of **Operations** and **Events** under sections 6.8.2.2 and 6.8.2.3, the **Distributor** may request the **User** to provide a written report of the **Significant Incident** according to the following requirements:

(a) **Distributed Generators**

When forced outages or any **Significant Incident** has occurred in the **Distributed Generator's Plant** which have or may have resulted in interruption of supplies to **Users** in the **Distributor's Distribution System** or had a significant effect on the **Distribution System** or the **System** of another **User**, as determined by the **Distributor**, the **Distributed Generator** shall verbally inform the **Distributor** of the **Operation** or **Event** under sections 6.8.2.2 and 6.8.2.3, providing the details of sequence of events known at that time leading to the supply interruption. Both parties shall immediately coordinate actions to restore supplies according to the required security levels. The **Distributed Generator** shall also provide a written report to the **Distributor** not less than seven (7) days after the **Significant Incident**.

(b) **Consumers**

Consumers taking supplies from the **Distributor** at **Medium Voltage** and having a **System** at the same and/or lower **Medium Voltage** may from time-to-time experience **Operations** or **Events** in their **System** that have a significant effect on the **Distributor's Distribution System** or the **System** of other **Users** as determined by the **Distributor**. If such a **Significant Incident** has occurred, the **Consumer** shall immediately verbally inform the **Distributor** of the **Significant Incident**, under sections 6.8.2.2 and 6.8.2.3, providing the details of sequence of events known at that time leading to the **Significant Incident**. The **Consumer** shall also provide a written report to the **Distributor** not less than seven (7) days after the **Significant Incident**.

(c) **Embedded Distributors**

Operations or **Events** occurring in an **Embedded Distributor's System** connected to the **Distributor's Distribution System** may have a significant effect on the **Distributor's Distribution System** and the **Distributor's Consumers**, as determined by the **Distributor**. If such a **Significant Incident** has occurred, the **Embedded Distributor** shall immediately verbally inform the **Distributor** of the **Significant Incident**, under sections 6.8.2.2 and 6.8.2.3, providing the details of sequence of events known at that time leading to the **Significant Incident**. The **Embedded Distributor** shall provide a written report to the **Distributor** not less than seven (7) days after the **Significant Incident**.

(d) Summary of significant incidents according to Users Category (**Distributed Generators/ Consumers/ Embedded Distributors**) shall be submitted by the **Distributor** to the **Commission** on a monthly basis.

6.8.3 Notification of Scheduled Outages and Interruptions

6.8.3.1 The **Distributor** shall inform **Users** of a scheduled supply interruption at least three days before the **Event** stating the date, time and duration of the interruption.

6.8.3.2 When a supply interruption has occurred due to a forced outage of **Equipment**, the **Distributor** shall make all reasonable efforts to provide accurate information to **Users** on the expected duration of the interruptions and the time that supplies will be restored.

6.8.4 Restoration of Supply

- 6.8.4.1 The **Distributor** in restoring supply to **Users** following supply interruptions shall meet the security level and operation criteria as specified in Section 6.5 of the **DOC**. When the supply interruption to **Users** is as a result of multiple contingencies, then the **Distributor** shall make all reasonable efforts to restore supply and if supply is not restorable within 12 hours, the **Distributor** shall make reasonable efforts to inform affected **Users** of the situation.

6.8.5 Recording System Outages and Interruptions

- 6.8.5.1 Each Distributor is required to establish a system of reporting and recording of Operations and Events involving outages of equipment and supply interruptions to Consumers and provide a summary of reliability performance indices as specified below and any other reliability indices as determined by the **Commission**. The procedure for the recording of such Operations and Events according to classifications, nature, modes and causes of failure shall be in accordance with prudent utility practices and/or any Licence Standard that the Distributor is required to prepare with the concurrence of the **Commission**. The Distributor shall provide to the **Commission**, a summary of the following reliability indices based on the recorded outages and supply interruptions on a quarterly basis for each station, each area and for its entire Distribution Area:

SAIFI: System Average Interruption Frequency Index for sustained interruption (excluding momentary interruptions) in interruptions/ customer over a pre-defined area and period of time.

SAIDI: System Average Interruption Duration Index for sustained interruptions momentary interruptions) in minutes/customer over a pre-defined area and period of time.

CAIDI: Customer Average Interruption Duration Index is the average time required to restore services to the average customer for sustained interruptions (excluding momentary interruptions) in minutes/ customer over a pre-defined area and period of time.

All interruptions (planned or unplanned) are reported & recorded for reliability index computation. Definitions of various categories of interruption are as follows:

- a. Any interruption lasting for one minute or less is classified as 'momentary' as a result of transient outage or switching operation.
- b. Any interruption lasting for more than one minute can be classified as 'sustained' or 'temporary'.
- c. 'Sustained interruption' – an interruption where supply to all affected customers is only restored when the outage component is repaired and normalized;
- d. 'Temporary Interruption' – an interruption where supply to all affected customers is restored before outage component is repaired and normalized.
- e. All interruptions including those triggered by the grid failures, which is beyond the responsibility and control of Distributors, have to be recorded and used in computing the reliability indices.

6.8.5.2 Reliability indices listed above relating to outages and supply interruptions shall be recorded and reported in line with any **Licence Standard** that the **Distributor** is required to prepare.

6.9 Demand Control and Emergency Operations

6.9.1 General

The GSO, under Section OC4 of the Grid Code for Peninsular Malaysia and Section OC4 of the Grid Code for Sabah and Labuan, to safeguard the integrity of the Grid System, may under an emergency situation or in anticipation of an emergency situation issue warnings and/or instructions to the Distributor to undertake Demand reduction which may include but is not limited to actions described in DOC 6.9.3, 6.9.4, 6.9.5, and 6.9.6 and the relevant sections of the Grid Code as follows:

- (a) reducing **Consumer Demand**;
- (b) disconnecting **Consumers**;

- (c) automatic under frequency load-shedding or disconnection;
- (d) automatic under voltage load- shedding or disconnection;
- (e) emergency manual disconnection of **Consumer Demand**; and
- (f) rota disconnections for energy saving.

6.9.2 Responsibilities of the Distributor and Users

6.9.2.1 The **Distributor** is responsible for planning and co-ordination with **Users** connected to the **Distribution System** in order to establish an **Emergency Load Curtailment Plan** to comply with the requirements of OC4 of the **Grid Code**. The **Emergency Load Curtailment Plan** shall include the following details:

- (a) quantum of **Demand** reduction, locations and effected **Users**;
- (b) circumstances and condition for implementing the load reductions for the scenarios in provision DOC section 6.9.1;
- (c) the required response from each **User** to the warnings issued by the **GSO** as specified in Section OC4 of the Sabah Grid Code; and
- (d) supply restoration procedure.

6.9.2.2 The **Emergency Load Curtailment Plan** shall also make provision for **Demand** control which may be required by the **Distributor** for emergency situations that may arise on the **Distribution System**.

6.9.2.3 On the request of the **GSO**, the **Distributor** shall furnish the **Emergency Load Curtailment Plan** to the **GSO** in a time frame as mutually agreed with the **GSO**.

6.9.2.4 **Users** are required to co-operate with the **Distributor** in the preparation and implementation of the **Emergency Load Curtailment Plan** and other emergency provisions made by the **Distributor** for safeguarding the **Distribution System** and/or **Grid System**.

6.9.3 Automatic Low Frequency Load Disconnection

6.9.3.1 The **GSO** may achieve demand reduction by means of under frequency load-shedding relays to disconnect **Demand** from the **Distribution System** in accordance with provision OC4.6 of the **Grid Code**. The **Grid System Operator** will, from to time inform the **Distributor** on the quantum (in percentage of the **Peak Demand**) of **Demand** to be disconnected at each step following continuous decline of **System** frequency. On receipt of this information from the **Grid System Operator**, the **Distributor** in consultation with **Users** connected to the **MV Distribution System** shall immediately review the **Emergency Load Curtailment Plan** and make appropriate changes to the load-shedding scheme. Upon the request of the **Grid System Operator**, the **Distributor** shall submit the revised **Emergency Load Curtailment Plan** in a reasonable time.

6.9.4 Automatic Low Voltage Load Disconnection

6.9.4.1 The **GSO** may also achieve demand reduction by means of under voltage load-shedding relays to disconnect **Demand** from the **Distribution System** in accordance with provision Section OC4.6 of Sabah Grid Code. The **Grid System Operator** will, from to time inform the **Distributor** on the quantum (in percentage of the **Peak Demand**) of **Demand** to be disconnected at each step following continuous decline of **System** voltage. On receipt of this information from the **Grid System Operator**, the **Distributor** in consultation with **Users** connected to the **MV Distribution System** shall immediately review the **Emergency Load Curtailment Plan** and make appropriate changes to the load-shedding scheme. Upon the request of the **Grid System Operator**, the **Distributor** shall submit the revised **Emergency Load Curtailment Plan** in a mutually agreeable timeframe.

6.9.5 Manual Disconnection of Users

6.9.5.1 The **Distributor** shall also include in the **Emergency Load Curtailment Plan** a list of **Demand / Users** to be disconnected manually as required under provision OC4.6 of Sabah Grid Code to meet emergency situations.

6.9.6 Rota Demand Control to Manage Longer Term Emergencies

6.9.6.1 The **Distributor** shall also include in the **Emergency Load Curtailment Plan** a list of rotas of **Demand / Users** to be disconnected as required under provision OC4.6 of Sabah Grid Code to meet longer term emergency situations such as fuel shortages.

6.9.7 Black Start

6.9.7.1 General

6.9.7.1.1 Provision OC7.4 of Sabah Grid Code specifies the **Grid System Restoration Plan** to be followed in the event of a **Partial Blackout** or **Total Blackout** of the **Grid System**. The plan utilises **Black Start Generating Units** to develop local Power Islands to progressively restore **Demand** and then to re-synchronise and interconnect Power Islands until the **Total System** is restored and interconnected.

6.9.7.1.2 During a **Black Start** recovery situation, the **Grid System Operator** shall initiate the implementation of the **Grid System Restoration Plan** and all **Users** will be required to operate according to the instructions of the **Distributor**.

6.9.7.2 Black Start Distributed Generating Units

6.9.7.2.1 **Black Start Generating Units** are mainly directly connected to the **Transmission System**; however, it is feasible that **Distributed Generators** could provide **Black Start** services and these **Embedded Generating Units** are termed as **Black Start Distributed Generating Units**.

6.9.7.2.2 Where the **Distribution System** contains **Black Start Generating Units**, the **Distributor** and the **Distributed Generators** with the advice of the **Grid System Operator** will be responsible for establishing a **Distribution System Recovery Plan** for recovery from a **Partial Blackout** or **Total Blackout** using the **Black Start Distributed Generating Units**. The objective of the **Distribution System Recovery Plan** is for the **Distributor** to restore supply to parts of the **Distribution System** in view of the likely protracted recovery time for the **Grid System** and as a contribution to the recovery of the **Grid System**. The **Distribution System Recovery Plan** shall include the following **System** details:

- (a) list of **Black Start Generating Units** and their capabilities and limits;
- (b) parts of the Distribution **System** to be supplied by individual **Distributed Generating Units** as separate islands;
- (c) synchronizing points between the islands and between the **Distribution System** and the **Grid System**.

6.9.7.2.3 During a **Black Start** recovery situation, the **Distributor** shall request permission of the **Grid System Operator** to initiate the implementation of the **Distribution System Recovery Plan** and all **Distributed Generators** and other **Users** will be required to operate according to the instructions of the **Distributor**.

6.9.7.2.4 For Black Start involving Islanded Grid in Sabah, refer to Specific Requirement for Sabah in 10.6.3.

6.10 Maintenance Coordination Requirements

6.10.1 General

6.10.1.1 It is necessary for the **Distributor** and **Users** connected to the **Distribution System** to maintain an up-to-date record of the network and equipment as well as to coordinate scheduled maintenance of equipment. This section provides requirements for the **Distributors**, **Distributed Generators**, **Consumers** and **Embedded Distributors** on maintaining information on **Distribution System Equipment** and **User System Equipment** and the need for exchange of this information as well as coordination of maintenance of **Equipment** including **Protection** equipment at the points of interface.

6.10.2 Maintaining Records on Distribution System User Equipment

6.10.2.1 The **Distributor** is responsible for maintaining information on **Distribution System Equipment** which includes but is not limited to the following:

- Cable/line routes along all public roads and access; and
- **Equipment** locations, types, makes and capacities.

6.10.2.2 The **Distributor**, on a written request by any person will provide the relevant parts of the information to the requesting person provided that the **Distributor** is satisfied that the purpose of such request is to safeguard the **Distributor's Equipment** and installation from any external damage due to the work that the requesting person intends to perform near the installation.

6.10.2.3 All **Distributed Generators, Consumers** and **Embedded Distributors** connected to the **Distribution System** are responsible for maintaining information of their respective **Equipment** including cable/lines routes, **Equipment** locations, types, the makes and capacities. On the request of the **Distributor**, such information shall be provided in a reasonable time.

6.10.3 **Maintenance Coordination of Equipment at the Point of Interfaces**

6.10.3.1 The **Distributor** is responsible for coordination of maintenance of **Equipment** at the points of interface with **Users** with the view to minimizing or eliminating a supply interruption to **Users** in accordance with the following:

- (a) where in the opinion of the **Distributor** the deferment of the scheduled outage is necessary then the **Distributor** will suggest to the **User** an alternative suitable date and time for the outage and unless the deferment is in conflict with requirements of the **User's** legal obligations or **Licence** condition, the **User** shall defer the outage according to the requirement of the **Distributor**; and
- (b) as far as possible scheduled outages resulting in a supply interruption shall be arranged during the period of low electricity **Demand**.

6.10.4 **Protection Equipment and Revenue Metering Equipment Maintenance**

6.10.4.1 Inspection, maintenance and test of **Protection Equipment** and **Revenue Metering Equipment** and associated control and ancillary equipment may require outages of primary equipment and/or a supply interruption. The **Distributor** is responsible for coordinating with **Users** regarding the maintenance of protective and metering equipment at the points of interface with the view to minimizing or eliminating a supply interruption to **Users** in accordance with the following:

- (a) inspection, test and maintenance of any protection or metering equipment shall where possible avoid the need for a supply interruption;
- (b) where in the opinion of the **Distributor** the deferment of the protection or metering equipment maintenance is necessary to avoid a supply interruption then the **Distributor** will suggest to the **User** an alternative suitable date and time for the outage and unless the deferment is in conflict with requirements of the **User's** legal obligations or **Licence** condition, the **User** shall defer the outage according to the requirement of the **Distributor**;

- (c) where reasonable, protection and metering equipment maintenance that will result in a supply interruption shall be arranged during the period of low electricity **Demand**.

6.10.5 Protection Equipment Coordination

6.10.5.1 The **Distributor** is responsible for ensuring that settings of protective relays in the **Distribution System**, at the points of interfaces with **Users** and inside the **System of Users** are coordinated to ensure selective operations of all relays irrespective of the location of the faults. The relevant parties will follow the procedure set out in 6.10.5.2 of the DOC when coordination of relay settings is to be carried out.

6.10.5.2 **Users** connected to the **MV Distribution System** are responsible for carrying out regular review of the relay settings of their generating plant and/or **System** including their interfaces with the **Distribution System** and shall also carry out a review whenever they intend to modify their **Protection** arrangements or settings. The **Distributor** may from time-to-time request from **Users** connected to the **MV Distribution System** the relay setting review report. **Users** are obliged to submit the report when a review is requested or modification to the **Protection** and/or **Protection** settings is being proposed by the **User** within a mutually agreeable timeframe

- (a) the relay setting review report shall include the proposed settings of all relays in the plant including at the point of interfaces with the **Distribution System**, reason for the settings, capability limits of all equipment in the plant, relay settings range and any other relevant information and assumptions pertaining to the **Protection** relay setting calculations;
- (b) on receipt of the relay setting review report, the **Distributor** will carry out an assessment of the impact of the settings on the **Distribution System** and if necessary, calculate new settings to ensure maximum security of supply and approve the changes suggested by the **User** if appropriate; and
- (c) the settings of the **User's Protection** can be changed to the settings approved by the **Distributor** only when the corresponding relays setting changes in the **Distribution System** have been made by the **Distributor**.

6.10.5.3 Notwithstanding the above requirements the **Distributor** and **Users** connected to the **Distribution System** shall be responsible for safeguarding and protecting their own equipment against any short- circuits and/or disturbances in both **Systems**.

Distribution Connection Code

7.1 Introduction

7.1.1 The **Distribution Connection Code (DCC)** specifies the technical, design, operational and data exchange requirements to be complied with by **Users** connected to or seeking connection to the **Distributor's Distribution System**.

7.2 Scope

7.2.1 The **DCC** applies to all **Distributors, Consumers, Distributed Generators** and **Embedded Distributors**. All **Distributors** and **Users** connected to the **Distributor's Distribution System** or seeking connection to the **Distributor's Distribution System** shall comply with the requirements of the **DCC**. For convenience the **DCC** is arranged in sections by **User** classification as follows:

- (i) General requirements for Connection.
- (ii) Connection Requirements for **Consumers** connected at **LV**.
- (iii) Connection Requirements for **Consumers** connected at **MV**.
- (iv) Connection Requirements for **Embedded Distributors**.
- (v) Connection Requirements for **Distributed Generators**

7.3 Objectives

7.3.1 The objectives of the Distribution Connection Code are:

- (a) to enable the **Distributor** to provide **Users** with a connection to the **Distribution System** through planning, design, construction, commissioning and operation to meet existing and planned loads and to meet the requirements of the **Electricity Supply Laws**, the **Licence** and the **Distribution Code, Sabah Grid Code**;
- (b) to specify the technical requirements of the **Distributor** and **Users** in relation to providing a **User** with a connection to the **Distribution System**; and
- (c) to establish requirements for exchange of data and information between the **Distributor** and **Users** to enable the **Distributor** to make an offer of connection.

7.3.2 Nothing in this **DCC** will displace the requirements of the **Electricity Supply Laws**, or **Licences**, to maintain the safety of personnel and the public, and to provide an economic, adequate and secure supply of electricity to **Users**.

7.4 General Requirements for Connection

7.4.1 Provision of an Electricity Supply to Users

7.4.1.1 Part VII of the **Enactment** imposes a duty on the **Distributor** to provide a supply of electricity, subject to certain provisions and exceptions. A connection to the **Distribution System** will be provided to a **User** by the **Distributor** exclusively under the terms of a **Connection Agreement** and such applicable “Tariff Categories” or “Riders” as from time to time may be approved by the **Minister**. A connection shall be supplied only at such **Connection Points** as are adjacent to the **Distributor’s** facilities which have adequate and suitable capacity and voltage for the service desired. Otherwise, special agreements between **User** and **Distributor** may be required.

7.4.2 Security and Quality of Supply

7.4.2.1 The **Distributor** will use reasonable diligence to supply a steady and continuous supply of electricity at the **Connection Point** in accordance with the security and power quality of supply requirements and planning and operation criteria set out in the **DPC** and **DOC**. On occasion irregularities or supply interruptions and short duration variations in voltage and frequency may occur as indicated in the **DPC** and **DOC**.

7.4.2.2 The **Distributor** and **User** may enter into special agreements for a higher or lower level of security of supply or power quality performance on terms that do not discriminate in favor of or against the **User**.

7.4.3 **Inspection of User Installations by the Distributor**

7.4.3.1 The **Distributor** reserves the right, but does not assume the duty, to inspect a **user's** installation at any time and refuse to supply or continue to supply an electricity service whenever the **Distributor** considers that the **User's** installation does not comply with the regulations governing that installation or the **Distribution Code**. In case of discontinuation of supply on grounds of non-compliance to regulations/Distribution Code, the Distributor shall provide in writing to the User details of noncompliance and action required to be taken by the User before supply can be restored. The **Distributor** does not assume any responsibility in connection with such installation or the inspection thereof. The **Distributor's** inspection or absence of it does not preclude any requirements established under law.

7.4.4 **Connection Point and Ownership Boundaries**

7.4.4.1 **Connection Point**

7.4.4.1.1 The design of connections between the **Distributor's Distribution System** and **Users** shall be in accordance with the planning and design criteria set out in **DPC5.4**, subject to any modifications to which the **Distributor** may reasonably consent.

7.4.4.1.2 Prior to signing the **Connection Agreement** and before making a connection to a **User** at a **Connection Point**, it will be necessary for the **Distributor** to be reasonably satisfied that the **User's System** at the interconnection point to the **Distributor's Distribution System** will comply with all appropriate requirements of the **Distribution Code**.

7.4.4.1.3 The **Connection Point** at which the connection is made between the **Distributor's Distribution System** and the **User's** installation will be in accordance with the following, or will be agreed between the **Distributor** and the **User** as required for special conditions.

- (a) **Low Voltage**: For supplies at **Low Voltage** of 230 volts or 400 volts, the general rule is that the **Connection Point** will be at the outgoing terminals of any isolating device immediately after the **Distributor's** owned metering equipment. The **User's** service terminals shall be installed in accordance with **Distributor's** specifications and be so located as to be readily accessible for connection to **Distributor's** service lines at a **Connection Point** to be determined by the **Distributor**.

- (b) **Medium Voltage:** For supplies at **Medium Voltages** of 11kV, or 33kV the **Connection Point** will be subject to specific agreement between the parties in each case. Normally, the **Connection Point** is the **Medium Voltage** busbar connecting the **Distributor's** isolating devices and the **User's** isolating devices. This will include those cases where a busbar connects supply at **Low Voltage**.
- (c) The **Connection Point** between a **Distributor** and **Embedded Distributor** shall be in accordance with provision 7.7.3.3 of the **DCC**.
- (d) The **Connection Point** between a **Distributor** and **Distributed Generator** shall be in accordance with provision 7.8.3.2 of the **DCC**.

7.4.4.2 Plant or Apparatus Ownership

- 7.4.4.2.1 The respective ownership of **Plant** and **Apparatus** at the interface is to be recorded in a written agreement between the **Distributor** and **User**. In the absence of a separate agreement between the parties stating otherwise, construction, commissioning, control, operation and maintenance responsibilities follow ownership.

7.4.5 User to Furnish Right of Way

- 7.4.5.1 The **User** at his own cost shall make or procure conveyance to the **Distributor** for a right-of-way or wayleave agreement, satisfactory to the **Distributor**, across property owned or controlled by the **User**, for the placement of the **Distributor's Equipment** for the purpose of providing an electricity service. (Access to land for construction, operation and maintenance of **Distributor's** facilities necessary or incidental to the supplying of electrical service to the **User** is provided for under part IV of the **Enactment**).

7.4.6 Service to Contiguous Property

- 7.4.6.1 Except with the written consent of the **Distributor**, the **User** shall not extend, or connect his installation to lines across or under a street, alley, lane, court, avenue or other public or private space, in order to obtain service for an adjacent property through one meter, even though such adjacent property is owned by the **User**.

7.4.7 **User to Protect Distributors Property**

7.4.7.1 The **User** shall protect all the **Distributor's** property on the **User's** premises and shall permit only the **Distributor's** agents or persons authorized by law to inspect or handle such property. The **User** shall be responsible for any loss or damage to such property of the **Distributor** resulting from carelessness, neglect or misuse by the **User** or by any member of this family, or by any agent, employee or representative of the **User**, or by other unauthorized persons on the **User's** premises with the **User's** knowledge and consent.

7.4.8 **Exchange of Data between User and Distributor**

7.4.8.1 The data exchange between the **User** and **Distributor** is specified in the **DPC** and **DOC** and in each section of this **DCC** relevant to each category of **User** and is summarized in the **Data Registration Code**. In all cases the data required may be greater than or less than that specified above and shall be sufficient for the **Distributor** to assess the impact of the proposed connection on the **Distribution System**. In case, the data required is more than that specified in the Distribution Code, the Distributor shall provide reasons while asking for the same.

7.4.8.2 **Declaration of Load Characteristics by a User**

7.4.8.2.1 To enable the **Distributor** to plan for connection of **Consumers, Distributed Generators** and **Embedded Distributors** to the **Distribution System**, the **Distributor** requires adequate information on the magnitude and characteristics of the loads or generation to be connected and **Users** are required to provide the data requested by the **Distributor**, more specifically set out in each section of this **DCC** applying to each category of **User**.

7.4.9 **Power Quality Disturbances**

7.4.9.1 The **User** shall not employ or utilize any **Equipment**, appliance, or device so as to adversely affect the **Distributor's** electricity supply to other **Users**. Where a **User** uses or intends to use the electricity supply for the operation of hoists, welding machines, x-ray machines, electric furnaces or ovens, variable frequency drives, AC to DC converters, saturable power transformers, motor starting, switching power supplies, equipment employing semiconductor switching technology or otherwise having load characteristics which produce harmonics, voltage step changes or voltage variations that may be outside the

limits specified in provisions of 5.4.6.6 of the **DPC**, or which otherwise may adversely affects voltage regulation, then the **User** shall may be required to install and maintain, suitable **Apparatus** or take action to limit the effect of such **Equipment** to such values as are permissible at the connection point.

7.4.10 **Limitation of Use by the User**

7.4.10.1 The electric service or energy supplied by the **Distributor** shall be used by the **User** subject to the limitations contained in the applicable “Tariff Schedule” or “Rider and Guidelines” as from time to time may be approved by **the Minister** and the **Connection Agreement** and within the capacity of the **Distribution System** at the **Connection Point**.

7.4.10.2 When the **Distributor** provides a polyphase service, the **User’s** load shall be maintained in electrical balance between phases at the **Connection Point** as specified in the section 5.4.6.6(c) of DPC. Single-phase motors in excess of 5 horsepower capacity shall not be connected without specific approval of the **Distributor**.

7.4.11 **Design Principles**

7.4.11.1 In planning the **Distribution System** for connections to a **User**, the **Distributor** shall plan the connection to satisfy the planning and design requirements of the **DPC** and the operation requirements of the **DOC** and in compliance with the **Electricity Supply Laws**, the **Licence**, any **Licence Standards** the **Distributor** is required to produce for the concurrence of the **Commission**, the **Distribution Code** and **Grid Code**.

7.4.11.2 The **User** shall be responsible for all electrical wiring and equipment on the **User’s** side of the **Connection Point** and all wiring, appliances, and **Apparatus** for the utilization of electric service on the **User’s** side of the **Connection Point** shall be installed by **Competent Persons** unless otherwise provided for in the Service Agreement or applicable Tariff Schedule or Rider and shall conform to the **Electricity Supply Laws** governing such installations and with the **Distribution Code** and **Grid Code**.

- 7.4.11.3 The **User** shall cooperate with the **Distributor** in the design of the **User's** electrical installation and provide all information requested by the **Distributor**, to ensure that the **Distribution System** is planned and can be operated in compliance with the **Electricity Supply Laws**, the **Licence**, any **Licence Standards** the **Distributor** is required to produce for the concurrence of the **Commission** and the **Distribution Code**.
- 7.4.11.4 The **Distributor** is entitled to assume that the information provided by the **Consumer** as requested by the **Distributor** is complete and accurate and that the **Consumer's** installation complies with the **Electricity Supply Laws** and the **Connection Agreement**.
- 7.4.11.5 No **Consumer** connected to the **Distribution System** shall connect a **Generating Unit** to operate in parallel with the **Distribution System** without the consent of the **Distributor**. Where a **Consumer** wishes to connect a **Generating Unit** to operate in parallel with the **Distribution System** the **Consumer** shall comply with the requirements of section 7.8 of the **DCC** (Connection Requirements for **Distributed Generators**).
- 7.4.11.6 Where a **Consumer** intends to connect a **Generating Unit** that does not operate in parallel with the **Distribution System** then adequate means shall be installed and used to prevent inadvertent parallel operation of the **Generating Unit** with the **Distribution System**.

7.5 Connection Requirements for Consumers Connected at LV

7.5.1 Declaration of Load and its Characteristics

- 7.5.1.1 For supplies at **Low Voltages** of 230V and 400V, the **Consumer** shall, in the appropriate application forms for connection obtainable from the **Distributor** provide the following data:
- (a) maximum power requirements in kVA;
 - (b) types and number of equipment and its corresponding connected load in kVA;
 - (c) shunt connected reactors and capacitors in kVAR;
 - (d) the date when connection is required; and
 - (e) for single-phase 230V motors with rating of greater than 6 KVA and/or three-phase 400V motors with rating greater than 75 kVA;

- (i) rating in HP or KVA;
- (ii) types of control equipment;
- (iii) methods of starting and starting current;
- (iv) frequency of starting (number/hour);
- (v) rated power factor; and
- (vi) voltage sensitive loads (indicating sensitivity)

7.5.1.2 Where a preliminary examination of the above data indicates that more detailed information is required, the **Consumer** shall provide additional information on the request of the **Distributor**. The Distributor shall provide reasons for asking for the same.

7.5.2 Technical Requirements for Connection

7.5.2.1 For connections at **Low Voltage** the **Consumer's** installation shall comply with the **Electricity Supply Laws** and Malaysian Wiring Regulations and standard requirements specified by the **Distributor** to ensure that the installation complies with the **Distribution Code**.

7.5.2.2 In the case of connections to **Consumers at Low Voltage**, the **Distributor** has the responsibility to specify any technical requirements for the connection. This includes specification of technical requirements associated with loads which may give rise to short duration voltage variation, and steady state voltage disturbances to ensure compliance with the limits specified in the provision 5.4.6.6 of the **DPC**.

7.6 Connection Requirements for Consumers Connected at MV

7.6.1 Declaration of Load and its Characteristics

7.6.1.1 For supplies at **Medium Voltages** of 11 Kv and 33 kV, the **Consumer** shall provide information on the loads and their characteristics including but not limited to the following:

- (a) For all types of loads:
 - i. Maximum **Active Power** consumption in kW; and
 - ii. Maximum **Reactive Power** consumption in kVAr.

- (b) For motor loads:
 - i. rating of motor (in HP/kVA)

-
- ii. types of control equipment;
 - iii. methods of starting;
 - iv. magnitude and duration of the starting current;
 - v. frequency of starting (number/hour);
 - vi. under voltage setting and time;
 - vii. negative phase sequence protection; and
 - viii. sub-transient and/or locked rotor reactance of the motor.
- (c) For nonlinear loads with harmonic current injections:
- i. harmonic current spectrum including harmonic number and the corresponding maximum current.
- (d) For fluctuating loads:
- i. The rates of change of **Active Power** and **Reactive Power** consumption in kW/minute and kVAr/minute respectively, both increasing and decreasing;
 - ii. The shortest repetitive time interval between fluctuations for **Active Power** and **Reactive Power** in minutes; and
 - iii. The magnitude of the largest step changes in **Active Power** and **Reactive Power** in kW and kVAr respectively, both increasing and decreasing.
- (e) For voltage sensitive loads:
- i. steady-state voltage tolerance limits of the equipment in percentage of the nominal voltage;
 - ii. intrinsic immunity limits to short duration voltage variation;
 - iii. transient voltage tolerance limits of the equipment in percentage of the nominal voltage and the corresponding duration;
 - iv. harmonic voltage distortion (THDV) tolerance limits for the equipment in % total harmonic distortion and individual harmonic distortion.
- (f) For Shunt Connected Reactors and Capacitors:
- i. Configuration, sizes, and point of connection of individual banks;
 - ii. types of switching and control equipment; and
 - iii. types of harmonic filtering reactors.

7.6.1.2 Should a preliminary examination of the above data indicate that more detailed information is required, the **Consumer** shall provide additional information on the request of the **Distributor**. The **Distributor** shall provide reasons for asking for the same.

7.6.2 Technical Requirements for Connection

7.6.2.1 The **Distributor** upon receipt of the information specified in provision 7.6.1.1 of the **DCC** shall perform an assessment of the impact of the load on the **Distributor's Distribution System** and if necessary, advise the **Consumer** to contain the impact of the **Consumer's** load in compliance with the limits and standards specified in **DPC** and **DOC** of the **Distribution Code**.

7.6.2.2 Certain types of **User Equipment** connected to the **Distributor's Distribution System** may give rise to voltage variations and/or voltage distortion which result in disturbance to other **Users** or damage to the **Distribution System** or connected **User Equipment**. Voltage variations include voltage step changes due to switching of **User** or **Distributor Demand** or **Equipment**, voltage flicker due to the operation of **User Equipment** such as welding machines and arc furnaces, **Voltage Unbalance** due to unbalanced loads. Harmonic voltage distortion may arise due to the connection of converters. In order to limit these effects both the **Distributors** and **Users** shall take into account their responsibilities as follows:

- (a) The **Distributor** shall through the planning and connection process maintain voltage variations due to step changes, flicker, **Voltage Unbalance** and harmonic distortion within the limits specified in asset out in provision 5.4.6.6.
- (b) The **User** shall maintain voltage distortion at points of common coupling (**PCC**) such that it does not result in voltage distortion in the **Distributor's Distribution System** beyond the limits specified in provision 5.4.6.6.
- (c) The **User** shall make an appropriate assessment of the impact of the connection of such **Equipment** to the **System** and take measures to limit the distortion of the supply voltage of the **Distributor's Distribution System** within the limits specified in provision 5.4.6.6.
- (d) The **User** shall inform the **Distributor** in reasonable time of the intention to connect **Equipment** likely to have a distorting effect on the **System** voltage and provide the **Distributor** with the information specified in the **Distribution Connection Code**.
- (e) The **Distributor** upon receipt of the above information shall make an appropriate assessment of the impacts of the connection of such **Equipment** to the **System** and recommend any further measures to be

undertaken by **Users** if necessary to limit the distortion of the supply voltage of the **Distributor's Distribution System** within the limits specified in provision 5.4.6.6.

- (f) The **Distributor** shall apply the best available engineering techniques and prudent utility practices in making such assessments following the procedures set out in the **Licence Standard** or where a **Licence Standard** has not been specified then the **Distributor** will comply with the relevant Malaysian Standards and **IEC Standards (IEC 61000 series)**.

7.6.2.3 Protection and Control Requirements

7.6.2.3.1 **Protection** requirements vary widely depending on practices and needs of the particular **Distribution System**. In all cases, the basic requirement is that the **Consumer's** arrangements for **Protection** at the **Connection Point**, including types of **Equipment** and **Protection** settings, shall be compatible with standard practices on the **Distributor's Distribution System**, comply with the requirements of section 5.7 of the **DPC** and shall take account of the following:

- (a) maximum clearance times (from fault current inception to fault clearing) shall be within the limits established by the **Distributor** in their short circuit rating policy for the **Distribution System**;
- (b) auto-reclosing or sequential switching features may be used on the **Distributor's Distribution System**. The **Distributor** will provide details on the operating sequence utilized for the supplies on the proposed installation so the **Consumer** can plan for this in the design and protection of his facility;
- (c) On some **Distribution systems**, e.g. lateral feeders or tee-offs, certain types of faults may cause disconnection of one phase only of a three-phase supply.

7.6.2.3.2 The **Protection facilities** and settings shall be approved by the **Distributor**.

7.6.2.3.3 The **Distributor** and **User** shall agree on the SCADA and other control and monitoring facilities required at the interface.

7.6.2.4 Earthing Requirements

7.6.2.4.1 Earthing arrangements at the interface shall be in accordance with the **Electricity Supply Laws** and shall be approved by the **Distributor**.

7.6.2.5 **Operational Requirements**

7.6.2.5.1 Operational arrangements shall be in accordance with the **DOC** and the **Distributor** and **Consumer** shall agree in writing the following:

- (a) requirements for demand forecasts in accordance with section 5.10 of the **DPC** and section 6.4 of the **DOC**;
- (b) ownership, operation and maintenance boundaries and responsibilities in accordance with provision 6.7.1.1 of the **DOC**;
- (c) numbering and nomenclature of all **Plant** and **Apparatus** at the interface substation in accordance with provision 6.7.1.2 of the **DOC**; and
- (d) operational liaison arrangements and exchange of information on the 24-hour communications arrangements between the **User** and **Control Centres**, if required.

7.7 **Connection Requirements for Embedded Distributors**

7.7.1 **General**

7.7.1.1 The purpose of the connection between **Distributors** is to provide a continuous supply from a **Distributor** to an **Embedded Distributor** or to provide backup and reliability to the **Embedded Distributor's Distribution System**. The connection may also be required to provide mutual support between the two **Distribution Systems** in which case both parties may be considered to be an **Embedded Distributor** of the other from time to time, according to the prevailing operating conditions and each will have responsibilities accordingly.

7.7.2 **Information to be Provided to the Distributor**

7.7.2.1 For planning of the connection with **Embedded Distributors**, the following information shall be provided to the **Distributor**:

- (a) maximum import / export in MW and MVA_r;
- (b) the configuration of the connection;
- (c) voltage control at the point of connection, if applicable; and
- (d) maximum and minimum 3-phase and single-phase to ground fault levels (MVA) at the point of interconnection before connection.

7.7.2.2 Should a preliminary examination of the above data indicate that more detailed information is required, the **Embedded Distributor** shall provide additional information on the request of the **Distributor**. The **Distributor** shall provide reasons for asking for the same.

7.7.3 Technical Requirements for Connection

7.7.3.1 General

7.7.3.1.1 The **Distributor** and **Embedded Distributor** shall cooperate in the planning and operation of the connection to ensure that their respective **Distribution Systems** are planned and operated in accordance with the **Electricity Supply Laws, Licence, Licence Standards, the Distribution Code and Grid Code**.

7.7.3.1.2 On receipt of a request from the **Embedded Distributor** the **Distributor** shall provide an offer of connection to satisfy the demand and quality of supply requested by the **Embedded Distributor**.

7.7.3.2 Connection Point and Ownership Boundary

7.7.3.2.1 The **Connection Point** between the **Distributor** and the **Embedded Distributor** shall be agreed in writing between the **Distributor** and **Embedded Distributor**. The supply will be from a distribution circuit with a nominal operating voltage of 33kV, 11kV or other voltage as may be agreed.

7.7.3.2.2 Having agreed a **Connection Point** and **Ownership Boundary** the **Distributor** and **Embedded Distributor** shall each be responsible for providing and operating and maintaining their own equipment either side of the **Connection Point**, unless otherwise agreed in writing.

7.7.3.3 Facilities at the Connection Point

7.7.3.3.1 Unless otherwise agreed, the connection between the **Distribution Systems** shall be by means of a manually operated, lockable, disconnecting device providing a visual break installed in close proximity to or at the **Connection Point**. Normally, this disconnecting device shall be provided, owned and maintained by the **Distributor** or **Embedded Distributor** and is to be arranged so that it can be locked in the fully open or closed position by a double locking arrangement accessible to authorized personnel of the **Distributor** and **Embedded Distributor**.

- 7.7.3.3.2 The disconnecting device, connection and connectors shall have a capacity in accordance with the contracted power interchange capability at the **Connection Point** and be the responsibility of the owner. Both the **Distributor** and the **Embedded Distributor** shall inspect and approve the installation. The **Distributors** may agree in writing to other arrangements and conditions for the connection.
- 7.7.3.3.3 The device at the **Connection Point** shall only be operated with the consent of the **Control Centres** of both the **Distributor** and **Embedded Distributor**
- 7.7.3.4 **Voltage Control**
- 7.7.3.4.1 The normal voltage variation on the Distribution System is specified in Section 5.4.4.1.1(a) of DPC.
- 7.7.3.4.2 The **Distributor** and **Embedded Distributor** shall be responsible for voltage regulation on its own **Distribution System**. Arrangements may be made for suitable automatic on-load tap changing or voltage regulating equipment installed at the **Connection Point** or on distribution circuits as necessary for providing an improved quality of supply.
- 7.7.3.5 **Protection Requirements**
- 7.7.3.5.1 The **Protection** arrangements shall be in accordance with the requirements set out in section 5.7 of the **DPC** and **Protection** facilities and settings shall be agreed by the **Distributor** and the **Embedded Distributor**.
- 7.7.3.5.2 The **Distributor** and **Embedded Distributor** shall:
- (a) have responsibility for protecting its own **Equipment** and **Distribution System** from the **Connection Point** onward so that faults or other disturbances in one **Distribution System** do not cause damage to the other's **Equipment**.
 - (b) assure the other party that faults on its **Distribution System** are cleared within the agreed clearance time so as not to cause operational problems to the other's **Distribution System**.
- 7.7.3.5.3 Backup **Protection** shall be provided as required to clear faults in case of primary **Protection** failure.

7.7.3.6 Earthing Requirements

7.7.3.6.1 Earthing arrangements at the interface shall be in accordance with the **Electricity Supply Laws** and shall be approved by the **Distributor** and **Embedded Distributor**.

7.7.3.7 Operational Requirements

7.7.3.7.1 Operational arrangements shall be in accordance with the **DOC** and the **Distributor** and **Embedded Distributor** shall agree the following in writing:

- (a) requirements for demand forecasts in accordance with the section 5.10 of the **DPC** and section 6.4 of the **DOC**;
- (b) ownership, operation and maintenance boundaries and responsibilities in accordance with 6.7.1.1 of the **DOC**;
- (c) numbering and nomenclature of all **Plant** and **Apparatus** at the interface substation in accordance with 6.7.1.2 of the **DOC**; and
- (d) operational liaison arrangements and exchange of information on the 24-hour communications arrangements between **Control Centres**.

7.7.3.8 Demand Control

7.7.3.8.1 The **Distributor** and **Embedded Distributor** shall cooperate and agree the arrangements for **Demand Control** and Emergency Operations in accordance with the provisions of section 6.9 of the **DOC**.

7.7.3.9 Power Factor

7.7.3.9.1 The minimum power factor at the **Connection Point** shall be maintained to not less than 90% lagging.

7.8 Connection Requirements for Distributed Generators

7.8.1 General

7.8.1.1 In addition to the requirements for connection set out in this section 7.8 of the **DCC**, a **Distributed Generator** is also required to comply with the relevant connection requirements for **Consumers** connected to the **Distribution System** at **LV** and **MV** set out in sections 7.5 and 7.6 respectively of the **DCC**.

7.8.1.2 Where the total output of **Generating Units** connected to the **MV Distribution System** at a single **Connection Point** exceeds 15 MW for Sabah then, in addition to the requirements set out in sections 5.9, 7.6 and 7.8 of the **DCC**, the **Distributed Generator** is also required to comply with the relevant **Grid Code** including the provision of information. Any information provided to the **GSO** relating to **Grid Code** requirements shall also be provided to the **Distributor**.

7.8.2 Information to be Provided to the Distributor

7.8.2.1 For the purposes of planning the connection of a **Distributed Generator** to the **Distribution System**, the **Distributor** requires sufficient information to model the generating plant and carry out engineering studies for determining the method of connection to be employed, the voltage level of connection and its impacts on the **Distribution System**. The **Distributed Generator** shall provide the following information to the **Distributor** for planning purposes.

- a) Details of the proposed connection point (geographical and electrical) and connection voltage.
- b) The number of generators
- c) The total capacity of the **Power Station** and auxiliary supplies under various operating conditions
- d) Existing and proposed **System** Single Line Diagram
- e) **For all Generating Units**
 - (i) terminal voltage;
 - (ii) rated kVA;
 - (iii) rated kW;
 - (iv) maximum **Reactive Power** sent out or minimum lagging power factor;
 - (v) maximum **Reactive Power** absorbed or minimum leading power factor;
 - (vi) type of **Generating Unit** – synchronous, asynchronous, and inverter.
 - (vii) type of prime mover;
 - (viii) type of voltage control;
 - (ix) **Generating Unit** sub-transient reactance;
 - (x) **Generating Unit** transformer details;
 - (xi) requirements for **Top-Up Supply** and/or **Standby Supply**.
 - (xii) Proposed synchronization point

7.8.2.2 Should a preliminary examination of the above data indicate that more detailed information is required, the **Distributed Generator** shall provide additional information as follows on the request of the **Distributor**. The Distributor shall provide reasons for asking for the additional information.

(a) For a **Generating Unit** with a capacity greater than 1 MW, the following additional information shall be provided to the **Distributor** by the **Distributed Generator**:

(i) a. **Synchronous Generating Unit** electric and mechanical data (all impedance (unsaturated) in p.u. of rating and time constants in seconds)

- Type of prime mover
- Rated MVA
- Rated MW
- **Generating Unit** rotor and turbine moment of inertia or inertia constant
- **Generating Unit** MW / MVA_r capability chart
- Type of excitation system
- Stator resistance
- Direct-axis sub-transient reactance
- Direct-axis transient reactance
- Direct-axis synchronous reactance
- Quadrature-axis sub-transient reactance
- Quadrature-axis transient reactance
- Quadrature-axis synchronous reactance
- Direct-axis sub- transient open circuit time constant
- Direct-axis transient open circuit time constant
- Quadrature-axis sub-transient open circuit time constant
- Quadrature-axis transient open circuit time constant
- Zero sequence resistance
- Zero sequence reactance
- **Generating Unit** open circuit saturation curve

b. Inverter

- Total Rated kW_p
- PV module Type
- Solar Panel Installation
- PV Inverter Type
- PV Inverter Power Factor

-
- Number of inverter
- (ii) Compliance to Standard **Generating Unit transformer data**
- Rated MVA
 - Rated Voltage
 - Rated Frequency
 - Voltage Ratio
 - % Resistance
 - % Reactance
 - Tap Range in p.u.
 - Tap Step in p.u.
 - Tap Changer Type: on-load or off-load
 - Vector Group
 - AVR Control Method
 - Method of Earthing
 - Basic Lightning Impulse Insulation level (BIL)
- (iii) **Automatic voltage regulator (AVR) data**
- A block diagram for model of the AVR including the data in gains, forward and feedback gains, time constant and voltage control limits and limit characteristics.
- (iv) **Speed governor and prime mover data**
- A block diagram for the model of the generating unit speed governor including its control parameters, time constants, gains, valve limits, temperature controls, deadbands, turbine rating, maximum and minimum power, penstock parameters, tunnel parameter, surge chamber parameters and all other relevant data.
- (v) Capacitance connected in parallel at % of rated output with stages and manual or automatic switching operation to be agreed by the Distributor.
- (vi) Auto reactor connected in parallel at % of rated output with stages and manual or automatic switching operation to be agreed by the Distributor.

Should a preliminary examination of the above data indicate that more detailed information is required, the **Distributed Generator** shall provide additional information on the reasonable request of the **Distributor**.

b) For Fixed Speed Asynchronous Induction **Generating Units** the following data may be required:

- Stator Current at unity power factor
- Stator Current max at lagging power factor
- Stator Current min at lagging power factor
- Magnetizing reactance
- Stator resistance
- Inner cage or running rotor resistance
- Inner cage or running rotor reactance
- Outer cage or standstill rotor resistance
- Outer cage or standstill rotor reactance
- For the above state whether derived from inner outer cage or running-standstill measurements
- Slip at rated output per unit
- Load torque-speed coefficient B
- Load torque-speed coefficient C
- Inertia constant for generator prime mover drive chain

Note:

The torque-speed (T-N) relationship is defined as:

$$T = T_0 (A + BN = CN^2) \text{ where } A = 1.0 - B - C$$

Therefore, only B & C are needed.

Alternatively, a per unit torque-speed curve can be provided.

- Describe method of adding star capacitance over the operating range
- Maximum starting current in Amps
- Starting Regime - Symmetrical RMS current at time t from energisation:
 - t = 0 ms
 - t = 50 ms
 - t = 200 ms
 - t = 1 s
 - t = 5 s
- The operating chart to show range of reactive import and export with compensation as a function of **Active Power**.
- Details of the turbine and governor model, described in block diagram form showing transfer functions of individual elements The **Distributed Generator** will need to provide the above characteristic for each asynchronous **Generating Unit** based on the number of pole sets (i.e., Two data sets are required for dual speed 4/6 pole machines).

7.8.2.3 For large sites, with multiple machines, the **Distributed Generator** may alternatively provide an equivalent network modelled as an asynchronous **Generating Unit** with matching **Generating Unit** Transformer at the **Connection Point**. This equivalent should also model the site electrical network and power factor correction, etc. Should a preliminary examination of the above data indicate that more detailed information is required, the **Distributed Generator** shall provide additional information on the request of the **Distributor**. The **Distributor** shall provide reasons for asking for the same.

7.8.3 Technical Requirements for Connection

7.8.3.1 General

7.8.3.1.1 The **Distributor** upon receipt of the information specified in provision 7.8.2 of the **DCC** shall perform an assessment of the impact of the generation on the **Distribution System** and if necessary, advise the **Distributed Generator** to contain the impact of the generation in compliance with the limits and standards specified in **DPC** and **DOC** of the **Distribution Code**.

7.8.3.2 Connection Point and Ownership Boundary

7.8.3.2.1 The **Connection Point** at which the **Distribution System** interface boundary is made between the **Distributor** and **Distributed Generator** shall be agreed in writing between the **Distributor** and **Distributed Generator**. The supply will be from a distribution circuit with a nominal operating voltage of 33kV, 11kV, or another voltage as may be agreed. Unless agreed otherwise, the connection shall be made by means of a manually operated, lockable, disconnecting device providing a visual break installed in close proximity to or at the **Connection Point**. Normally, if the connection is on the **Distribution System**, this disconnecting device shall be furnished by the **Distributed Generator**, and handed over to the **Distributor** as specified in the "Technical & Operational Requirements". The device shall be owned and maintained by the **Distributor** and is to be arranged so that it can be locked in the fully open or closed position by a double locking arrangement and only accessible to authorized personnel of the **Distributor**.

7.8.3.2.2 The disconnecting device, connection and the connectors shall be sized in accordance with the contacted interchange capability. The **Distributor** and **Distributed Generator** may agree, in writing, to other arrangements and conditions for the connection.

7.8.3.2.3 For DG connected to LV of the Distribution System where disconnecting device with visual break is not possible, the disconnection circuit shall contain self-monitoring at the point of disconnection.

7.8.3.2.4 Appropriate interlocking between DG and the Connection Point shall be provided such as to prevent undesired safety hazard.

7.8.3.2.5 All necessary communication equipment for protection purposes as maybe required by the Protection relaying schemes shall be compatible with the applicable communication equipment of the Distributor.

7.8.3.3 **Generating Unit Specifications**

7.8.3.3.1 A **Generating Unit** with a capacity greater than 12 kVA or as specified by the **Distributor** shall be a three-phase **Generating Unit**.

7.8.3.3.2 Any generation, utilizing a direct current (dc) generating device and an inverter, shall be capable of supplying energy with a sine wave with a Total Harmonic Distortion i.e., the RMS sum of all harmonics superimposed on the 50 Hertz sine wave, not exceeding 5%, as calculated and/or measured at the **Connection Point** with no other **Users** connected. The RMS harmonic distortion from any individual harmonic shall be limited to 1% - 1.5% as specified by the **Distributor**.

7.8.3.3.3 In addition, the **Generating Unit** shall not produce harmonics of a magnitude and frequency so as to interfere with communication and electronic equipment.

7.8.3.4 **Connection Requirements**

7.8.3.4.1 Planning, design and operating requirements of **Distributed Generation** vary widely depending on practices and needs of the **Distribution System**. In all cases, the basic requirement is that the generation shall be compatible with planning and criteria specified in section 5.4 of the **DPC** and the operation criteria specified in section 6.5 of the **DOC** and the standard practices on the **Distributor's Distribution System**. The particular technical requirements for connection will be as agreed in writing by the **Distributor** and shall cover the following:

- (a) Voltage control;
- (b) Fault levels;
- (c) Network capacity and export / import limits;
- (d) Interconnection facility
- (e) Active and Reactive Power requirement
- (f) Supply quality;
- (g) Protection including minimum clearance times
- (h) Control including any requirement for SCADA facilities;
- (i) Earthing;
- (j) Generator Neutral earthing
- (k) Generator Capability Chart
- (l) Transformer winding configurations;
- (m) Stability, where necessary;
- (n) Synchronizing arrangements; and
- (o) Operation and safety.
- (p) Anti islanding technique
- (q) Interlocking facility
- (r) General scope of work required

7.8.3.4.2 Synchronising of the distributed generating units to the distribution system shall be done automatically. Manual synchronising can only be carried out with the specific agreement of the Distributor.

7.8.3.5 Protection and Control Requirements

7.8.3.5.1 It will be necessary for the **Protection** associated with **Distributed Generating Plant** to co-ordinate with the **Protection** associated with the **Distribution System** as follows:

- (a) maximum clearance times (from fault current inception to fault clearing) shall be within the limits established by the **Distributor** in their short circuit rating policy for the **Distribution System**;
- (b) auto-reclosing or sequential switching features may be used on the **Distribution System**. The **Distributor** will provide details on the operating sequence utilized for the supplies on the proposed installation so the **Consumer** can plan for this in the design and protection of his facility; and
- (c) On some **Distribution systems**, e.g., lateral feeders or tee-offs, certain types of faults may cause disconnection of one phase only of a three-phase supply.

- (d) DG plant shall be isolated during Distributor loss of mains event. The following detection shall be made available:
- I. Inverter based generation:
 - i. Under voltage, over voltage
 - ii. Under frequency over frequency
 - iii. Active or passive anti islanding
 - II. Generator based:
 - i. Under voltage, over voltage
 - ii. Under frequency over frequency
 - iii. Rate Of Change Of Frequency (ROCOF)
 - iv. Vector shift

7.8.3.5.2 The **Protection facilities** and settings shall be approved by the **Distributor**.

7.8.3.5.3 The **Distributor** and **User** shall agree on the SCADA and other control and monitoring facilities required at the interface.

7.8.3.6 **Operational Requirements**

7.8.3.6.1 Operational arrangements shall be in accordance with the **DOC** and the **Distributor** and **Distributed Generator** shall agree the following in writing:

- (a) requirements for demand forecasts in accordance with the section 5.10 of the **DPC** and section 6.4 of the **DOC**;
- (b) ownership, operation and maintenance boundaries and responsibilities in accordance with 6.7.1.1 of the **DOC**;
- (c) numbering and nomenclature of all **Plant** and **Apparatus** at the interface substation in accordance with 6.7.1.2 of the **DOC**; and
- (d) operational liaison arrangements and exchange of information on the 24-hour communications arrangements between Authorized Personnel from both parties.
- (e) Typical switching of scheduled and unscheduled outage.

7.8.3.7 **Demand Control**

7.8.3.7.1 The **Distributor** and **Distributed Generators** shall cooperate and agree the arrangements for Emergency Operations in accordance with the provisions of section 6.9 of the **DOC**.

7.8.3.8 **Power Factor**

7.8.3.8.1 The Distributed Generator shall be responsible for maintaining the plant power factor within the limit specified by the Distributor. The provided power factor compensation device shall be of a type that is continuously adjustable to support voltage at the connection point due to normal voltage fluctuation profile.

7.8.3.8.2 Switched reactors may be installed within the DG facility. However, the DG plant power factor shall not be lower than 0.9 leading.

7.8.4 **Standby and Top Up Supply**

7.8.4.1 Where a **Distributed Generator** requires **Standby Supply** or **Top Up Supply**, the **Distributed Generator** shall provide information on the nature of the supply required and will comply with the relevant sections of the **DPC** and **DOC** fulfilling the requirements both as a **Consumer** and as a **Distributed Generator**.

Distribution Data Registration Code

8.1 Introduction

8.1.1 The various sections of the **Distribution Code** require the **Distributors** and **Users** to exchange and update data from time to time. The data specified in each section of the **Distribution Code**, where appropriate, is summarized in schedules in the **Distribution Data Registration Code (DDRC)** for each class of **User**.

8.1.2 Some of the data specified in the **Distribution Code** is indicative of the data that may be required by a **Distributor** and in this case the **Distributor** will provide his own schedules for that data.

8.2 Scope

8.2.1 The **DDRC** applies to the **Distributor** and to all **Users** which for the purpose of the **DDRC** are listed below:

- (a) **Consumers**. (However, Consumers connected to the **Distribution System** at **Low Voltage** will provide all the information through the standard application form of the **Distributor** and the **Distributor** will request any additional information required).
- (b) **Embedded Distributors** connected to the **Distributor's Distribution System**.
- (c) **Distributed Generators**
- (d) Any other person who makes application for use of or connection to the **Distribution System**.

8.3 Objectives

8.3.1 The objective of the **DDRC** is to collate and list in a readily identifiable form all the data to be provided by:

- (a) Each category of **User** to the **Distributor** under the **Distribution Code**.
- (b) The **Distributor** to each category of **User** under the **Distribution Code**.

8.4 Procedures and Responsibilities

8.4.1 Responsibility for Submission and Updating of Data

8.4.1.1 In accordance with the provisions of the various sections of the **Distribution Code** and unless otherwise agreed or specified by the **Distributor**, each **User** is required to submit data as defined in the **DDRC Schedules**.

8.4.2 Methods of Submitting Data

8.4.2.1 Data shall be submitted to the **Distributor** in writing and where possible in the format specified by the **Distributor** and shall indicate the name of the person who is submitting the data.

8.4.2.2 The **Distributor** will supply data as requested by **Users** and as agreed by the **Distributor** where no obligation of confidentiality exists.

8.4.3 Changes to User's Data

8.4.3.1 If a **User** wishes to change any data item, then this shall first be discussed with the **Distributor** concerned in order for the implications to be considered and the change if agreed (such agreement not to be unreasonably withheld), shall be confirmed by the submission of a revised data schedule by verbal means with confirmation in writing if short timescales are involved.

8.4.3.2 Whenever a **User** becomes aware of a change to an item of data, which is registered with the **Distributor**, the **User** shall notify the **Distributor** in accordance with the appropriate section of the **Distribution Code**. The method and timing of the notification to the **Distributor** are set out in the appropriate section of the **Distribution Code**.

8.4.4 Data Accuracy

8.4.4.1 The **User** is solely responsible for the accuracy of data (or of changes to data) supplied to the **Distributor**.

8.4.5 **Estimated Data**

8.4.5.1 Any data which the **User** fails to supply when required by any section of the **Distribution Code**, may be estimated by the **Distributor** if and when, in the **Distributor's** view, it is necessary to do so. Such estimates will be based upon data supplied previously for the same **Plant** or **Apparatus** or upon corresponding data for similar **Plant** or **Apparatus** or upon such other information as the **Distributor** deems appropriate.

8.4.5.2 The **Distributor** will advise a **User** in writing of any estimated data it intends to use pursuant to provision 8.4.5.1 of the **DDRC** relating directly to that **User's Plant** or **Apparatus** in the event of data not being supplied. The **Distributor** will not be liable as a result of using that estimated data; the responsibility for the accuracy of that data will rest with the **User** as if the data had been supplied by that **User**.

8.5 **Data to be Registered**

8.5.0 **General**

8.5.0.1 Schedules 1 to 4 are not used in this Distribution Code.

8.5.1 **System Planning Demand Forecasts – Schedule 5**

8.5.1.1 Form 5A of Schedule 5 specifies the detailed **Demand** forecast information to be submitted by the **Distributor** to the **Grid System Operator**.

8.5.1.2 Form 5B of Schedule 5 of the **Data Registration Code** specifies the detailed **Demand** forecast information to be submitted to the **Distributor** by a **Consumer** having a **Demand** of 3 MW for Sabah, or more.

8.5.1.3 Form 5C of Schedule 5 of the **Data Registration Code** specifies the detailed **Demand** forecast information to be submitted to the **Distributor** by an **Embedded Distributor**.

8.5.1.4 Form 5D of Schedule 5 of the **Data Registration Code** specifies the detailed **Demand** forecast information to be submitted to the **Distributor** by a **Distributed Generator** with a generation output of 1 MW or more.

8.5.1.5 Form 5E of Schedule 5 of the **Data Registration Code** specifies the load profile data to be recorded by the **Distributor**, the required recording period and the parameters to determine from the load profile.

8.5.1.6 Form 5F of Schedule 5 of the **Data Registration Code** specifies in detail the power quality related data to be recorded by the **Distributor**, the required recording period and the parameters to be determined from the recorded data.

8.5.2 Operational Demand Forecast Data – Schedule 6

8.5.2.1 Form 6B of Schedule 6 specifies the detailed information to be submitted to the **Distributor** by a **Consumer** having a **Demand** of 3 MW for Sabah or more to inform of the change in operational **Demand** forecasts.

8.5.2.2 Form 6C of Schedule 6 specifies the detailed information to be submitted to the **Distributor** by an **Embedded Distributor** to inform of the change in operational **Demand** forecasts.

8.5.2.3 Form 6D of Schedule 6 specifies the detailed information to be submitted to the **Distributor** by a **Distributed Generator** with a generation output of 1 MW or more to inform of the change in operational **Demand** forecasts.

8.5.2.4 Reliability indices relating to outages and supply interruptions shall be recorded and reported in line with any **Licence Standard** that the **Distributor** is required to prepare.

8.5.3 Load Characteristics and Connection Data

8.5.3.1 Connection data will be provided as specified in the **Distribution Connection Code** or as more particularly defined by each **Distributor** in application forms for connection.

8.5.4 Data Schedules

8.5.4.1 List of Data Schedules Form:

(i) **Schedule 5**

(a) **Form 5A – Distributors Load Forecast to the Grid System Operator**

- (b) **Form 5B – Consumer Load forecast to the Distributor**
 - (A) Forecast of typical weekly demand profile in MW and MVAR
 - (B) Monthly energy consumption in MWh and the corresponding monthly peak demand in MW and MVAR
 - (C) Demand forecast in MW, MVAR and energy MWh.

- (c) **Form 5C – Embedded Distributor Load Forecast to the Distributor**
 - (A) Typical weekly import/export⁺ demand profile
 - (B) Monthly energy import/export⁺ in MWh and MW/MVAR
 - (C) Annual import/export⁺ demand forecast in MW and MVAR

- (d) **Form 5D – Distributed Generator with Output of 1 MW or more – Load Forecast to the Distributor**
 - (A) Typical weekly output of the unit
 - (B) Forecast of the generating maximum MW, MVAR and annual MWh output

- (e) **Form 5E – Load profiles at the point of interfaces**
 - (A) For each incoming Feeders
 - (B) For each outgoing Feeders

- (f) **Form 5F – Power Quality Records**
 - (A) Voltage Harmonic Distortion (%)
 - (B) Annual incidents/expected voltage sags
 - (C) Annual incidents expected voltage swells
 - (D) Annual incidents of Flicker

- (ii) **Schedule 6**
 - (a) **Form 6B – Consumer Load Forecast Changes to the Distributor**
 - (A) Changes in Forecast of typical weekly demand in MW and MVAR
 - (B) Changes in Monthly energy consumption in MWh and the corresponding monthly peak demand in MW and MVAR

-
- (b) **Form 6C - Changes Embedded Distributor Load Forecast to the Distributor**
 - (A) Changes in Typical weekly import/export+ demand profile
 - (B) Changes in Monthly energy import/export+ in MWh and MW/MVAR

 - (c) **Form 6D - Distributed Generator Load Forecast Changes**
 - (A) Changes in Forecast of Typical weekly output of the unit
 - (B) Changes in scheduled monthly generation output

**Schedule 5 – Form 5A: Distributors Load Forecast to the Grid System Operator
(Submitted for each bulk transmission substation or transmission main intake substation)**

a. Distributor Name: _____

b. Bulk Transmission substation Name: _____

c. Date: _____

No.	Year	Mw ⁺	MVA ⁺	MWh [#]	Remarks [*]
Short-term					
1					
2					
Medium-term					
3					
4					
5					
Long-term					
6					
7					
9					
10					

+ MW and MVA⁺ are the expected maximum for the year

MWh is the total annual energy demand

* Remarks shall state any of the following:

- (a) shifting of loads to other bulk transmission substations;
- (b) upgrade of the bulk transmission substations; or
- (c) any other network changes affecting the forecast,

Schedule 5 – Form 5B: Consumer Load Forecast to the Distributor(Submitted by User under provision 5.10.2.1)

a. Consumer Name: _____

b. Address of Plant: _____

(A) Forecast of typical weekly Demand profile in MW and MVAR.

Time	MW	MVAR		Time	MW	MVAR
Monday						
00:00				12:30		
00:30				13:00		
01:00				13:30		
01:30				14:00		
02:00				14:30		
02:30				15:00		
03:30				15:30		
04:00				16:00		
04:30				16:30		
05:00				17:00		
05:30				17:30		
06:00				18:00		
06:30				18:30		
07:00				19:00		
07:30				19:30		
08:00				20:00		
08:30				20:30		
09:00				21:00		
09:30				21:30		
10:00				22:00		
10:30				23:00		
11:00				23:00		
11:30				23:30		
12:00				00:00		

Schedule 5 - Form 5B

Time	MW	MVAR		Time	MW	MVAR
* _____						
00:00				12:30		
00:30				13:00		
01:00				13:30		
01:30				14:00		
02:00				14:30		
02:30				15:00		
03:30				15:30		
04:00				16:00		
04:30				16:30		
05:00				17:00		
05:30				17:30		
06:00				18:00		
06:30				18:30		
07:00				19:00		
07:30				19:30		
08:00				20:00		
08:30				20:30		
09:00				21:00		
09:30				21:30		
10:00				22:00		
10:30				23:00		
11:00				23:00		
11:30				23:30		
12:00				00:00		

* Use the same form Tuesday, Wednesday, Thursday, Friday, Saturday and Sunday.

Schedule 5 - Form 5B

(B) Monthly energy consumption in MWh and the corresponding monthly peak demand in MW and MVAR

Year (Distributor's next financial): _____

No.	Month	Mw ⁺	MVAr ⁺	MWh [#]	Remarks
1					
2					
3					
4					
5					
6					
7					
8					
9					
10					
11					
12					

+ MW and MVAr are the expected maximum for the month

* MWh is the total monthly energy consumption

Schedule 5 - Form 5B

(C) Demand forecast in MW, MVAR and energy MWh.

No.	Year	MW ⁺	MVAr ⁺	MWh [#]	Remarks
Short-term					
1					
2					
Medium-term					
3					
4					
5					

+ MW and MVAr are the expected maximum for the year

* MWh is the total annual energy consumed

Schedule 5 – Form 5C: Embedded Distributor Load Forecast to the Distributor (Submitted by User under provision 5.10.3.1)

a. Submitting Distributor Name: _____

b. Receiving Distributor Name: _____

(A) Typical weekly import/export⁺ demand profile

⁺ Delete where not applicable

Time	MW	MVAR		Time	MW	MVAR
Monday						
00:00				12:30		
00:30				13:00		
01:00				13:30		
01:30				14:00		
02:00				14:30		
02:30				15:00		
03:30				15:30		
04:00				16:00		
04:30				16:30		
05:00				17:00		
05:30				17:30		
06:00				18:00		
06:30				18:30		
07:00				19:00		
07:30				19:30		
08:00				20:00		
08:30				20:30		
09:00				21:00		
09:30				21:30		
10:00				22:00		
10:30				23:00		
11:00				23:00		
11:30				23:30		
12:00				00:00		

Schedule 5 - Form 5C (continued)

Time	MW	MVAR		Time	MW	MVAR
* _____						
00:00				12:30		
00:30				13:00		
01:00				13:30		
01:30				14:00		
02:00				14:30		
02:30				15:00		
03:30				15:30		
04:00				16:00		
04:30				16:30		
05:00				17:00		
05:30				17:30		
06:00				18:00		
06:30				18:30		
07:00				19:00		
07:30				19:30		
08:00				20:00		
08:30				20:30		
09:00				21:00		
09:30				21:30		
10:00				22:00		
10:30				23:00		
11:00				23:00		
11:30				23:30		
12:00				00:00		

* Use the same form Tuesday, Wednesday, Thursday, Friday, Saturday and Sunday.

Schedule 5 - Form 5C (continued)

(B) Monthly energy import/export + in MWh and MW/MVAR

+ Delete where not applicable

Year (Receiving Distributor's next financial): _____

No.	Month	MW ⁺	MVAr ⁺	MWh [#]	Remarks
1					
2					
3					
4					
5					
6					
7					
8					
9					
10					
11					
12					

+ MW and MVAr are the expected maximum for the month

* MWh is the total monthly energy consumption/supplied

Schedule 5 - Form 5C (continued)

(C) Annual import/export⁺ demand forecast in MW and MVAR⁺ Delete where not applicable

No.	Year	MW ⁺	MVAR ⁺	MWh [#]	Remarks
Short-term					
1					
2					
Medium-term					
3					
4					
5					

⁺ MW and MVAR are the expected maximum for the year[#] MWh is the total energy imported/exported

Schedule 5 – Form 5D: Distributed Generator Plant with output of 1 MW or more – Load Forecast to the Distributor

a. Generator Name: _____

b. Generator Unit Name: _____

c. Date: _____

(A) Forecast of typical weekly output of the unit

Time	MW	MVAR		Time	MW	MVAR
Monday						
00:00			Monday	12:30		
00:30				13:00		
01:00				13:30		
01:30				14:00		
02:00				14:30		
02:30				15:00		
03:30				15:30		
04:00				16:00		
04:30				16:30		
05:00				17:00		
05:30				17:30		
06:00				18:00		
06:30				18:30		
07:00				19:00		
07:30				19:30		
08:00				20:00		
08:30				20:30		
09:00				21:00		
09:30				21:30		
10:00				22:00		
10:30				23:00		
11:00				23:00		
11:30				23:30		
12:00				00:00		

Schedule 5 - Form 5D (continued)

Time	MW	MVAR		Time	MW	MVAR
* _____						
00:00				12:30		
00:30				13:00		
01:00				13:30		
01:30				14:00		
02:00				14:30		
02:30				15:00		
03:30				15:30		
04:00				16:00		
04:30				16:30		
05:00				17:00		
05:30				17:30		
06:00				18:00		
06:30				18:30		
07:00				19:00		
07:30				19:30		
08:00				20:00		
08:30				20:30		
09:00				21:00		
09:30				21:30		
10:00				22:00		
10:30				23:00		
11:00				23:00		
11:30				23:30		
12:00				00:00		

* Use the same from Tuesday, Wednesday, Thursday, Friday, Saturday, and Sunday

Schedule 5 - Form 5D (continued)

(B) Forecast of the generating maximum MW, MVAR and annual MWh output

No.	Year	MW ⁺	MVAR ⁺	MWh [#]	Remarks
Short-term					
1					
2					
Medium-term					
3					
4					
5					

+ MW and MVAR are the expected maximum for the year

* MWh is the total annual energy output

Schedule 5 – Form 5E: Load profiles at the point of interfaces

(i) Interface Point Name: _____

(ii) Wednesday, Date: _____

(A) For Each Incoming Feeders

Time	MW	MVAR	Voltage (kV)		Time	MW	MVAR	Voltage (kV)
00:00					12:30			
00:30					13:00			
01:00					13:30			
01:30					14:00			
02:00					14:30			
02:30					15:00			
03:30					15:30			
04:00					16:00			
04:30					16:30			
05:00					17:00			
05:30					17:30			
06:00					18:00			
06:30					18:30			
07:00					19:00			
07:30					19:30			
08:00					20:00			
08:30					20:30			
09:00					21:00			
09:30					21:30			
10:00					22:00			
10:30					23:00			
11:00					23:00			
11:30					23:30			
12:00					00:00			

Schedule 5 - Form 5E (continued)

Time	MWh	MVARh		Time	MWh	MVARh
00:00				12:30		
00:30				13:00		
01:00				13:30		
01:30				14:00		
02:00				14:30		
02:30				15:00		
03:30				15:30		
04:00				16:00		
04:30				16:30		
05:00				17:00		
05:30				17:30		
06:00				18:00		
06:30				18:30		
07:00				19:00		
07:30				19:30		
08:00				20:00		
08:30				20:30		
09:00				21:00		
09:30				21:30		
10:00				22:00		
10:30				23:00		
11:00				23:00		
11:30				23:30		
12:00				00:00		

(B) For Each Incoming Feeders

Feeder nominal voltage (line-to-line): _____ kV

Time	MW	MVAR	Current (A)		Time	MW	MVAR	Current (A)
00:00					12:30			
00:30					13:00			
01:00					13:30			
01:30					14:00			
02:00					14:30			
02:30					15:00			
03:30					15:30			
04:00					16:00			
04:30					16:30			
05:00					17:00			
05:30					17:30			
06:00					18:00			
06:30					18:30			
07:00					19:00			
07:30					19:30			
08:00					20:00			
08:30					20:30			
09:00					21:00			
09:30					21:30			
10:00					22:00			
10:30					23:00			
11:00					23:00			
11:30					23:30			
12:00					00:00			

For reading in (A) calculate the following:

- (i) Load Factor: _____
- (ii) Load Loss Factor: _____

For readings in (B) calculate the following:

- (iii) Load Factor: _____
- (iv) Load Loss Factor: _____

Schedule 5 - Form 5F

Schedule 5 – Form 5F: Power Quality Records

(A) Voltage Harmonic Distortion (%)

i. Location of measurement: _____

ii. Voltage: _____ kV

iii. Date of measurement: _____ Time: _____

iv. Table of harmonic voltage spectrum.

Harmonic no. (h)	Voltage (p.u.) (V)		Harmonic no. (h)	Voltage (p.u.) (V)
1			12	
2			13	
3			14	
4			15	
5			16	
6			17	
7			18	
8			19	
9			20	
10			21	
11				

Total harmonic distortion, THD % = _____

Schedule 5 - Form 5F

(B) Annual incidents/expected voltage sags

i. Location of measurement: _____

ii. Nominal Voltage: _____ kV

iii. Year: _____

Sag (%)	No. of Sags with Duration Range in milliseconds					
	< 100	>100 <200	>200 <300	>300 <400	>400 <500	>500
≥ 90%						
≥ 80% <90%						
≥ 70% <80%						
≥ 60% <70%						
≥ 50% <60%						
≥ 40% <50%						
≥ 30% <40%						
< 30%						

Schedule 5 - Form 5F (continued)

(C) Annual incidents/expected

i. Location of measurement: _____

ii. Nominal Voltage: _____ kV

iii. Year: _____

Swell (%)	No. of Swells with Duration Range in milliseconds					
	< 100	>100 <200	>200 <300	>300 <400	>400 <500	>500
≥200%						
≥190% <200%						
≥180% <190%						
≥170% <180%						
≥160% <170%						
≥150% <160%						
≥140% <150%						
≥130% <140%						

Schedule 5 - Form 5F (continued)

(D) Annual Incidents of Flicker

i. Location of measurement: _____

ii. Nominal Voltage: _____ kV

iii. Year: _____

Date & Time	Flicker Pst			Flicker Plt		
	L1N	L2N	L3N	L1N	L2N	L3N
	Pst	Pst	Pst	Plt	Plt	Plt
02/07/2013 16:30:00	0.13	0.13	0.12	0.13	0.14	0.13
02/07/2013 16:40:00	0.10	0.10	0.10	0.13	0.14	0.13
02/07/2013 16:50:00	0.15	0.15	0.13	0.13	0.14	0.13
02/07/2013 17:00:00	0.13	0.13	0.10	0.13	0.14	0.13

**Schedule 6 – Form 6B: Consumer Load Forecast Changes to the Distributor
(Submitted by Consumer under provision 6.4.2.2)**

a. Consumer Name: _____

b. Address of Plant: _____ Date: _____

(A) Changes in Forecast of typical weekly demand in MW and MVAR

Time	Previously Submitted		Changes		Time	Previously Submitted		Changes	
	MW	MVAR	MW	MVAR		MW	MVAR	MW	MVAR
Monday									
00:00					12:30				
00:30					13:00				
01:00					13:30				
01:30					14:00				
02:00					14:30				
02:30					15:00				
03:30					15:30				
04:00					16:00				
04:30					16:30				
05:00					17:00				
05:30					17:30				
06:00					18:00				
06:30					18:30				
07:00					19:00				
07:30					19:30				
08:00					20:00				
08:30					20:30				
09:00					21:00				
09:30					21:30				
10:00					22:00				
10:30					23:00				
11:00					23:00				
11:30					23:30				
12:00					00:00				

Schedule 6 - Form 6B (continued)

Time	Previously Submitted		Changes		Time	Previously Submitted		Changes	
	MW	MVAR	MW	MVAR		MW	MVAR	MW	MVAR
* _____									
00:00					12:30				
00:30					13:00				
01:00					13:30				
01:30					14:00				
02:00					14:30				
02:30					15:00				
03:30					15:30				
04:00					16:00				
04:30					16:30				
05:00					17:00				
05:30					17:30				
06:00					18:00				
06:30					18:30				
07:00					19:00				
07:30					19:30				
08:00					20:00				
08:30					20:30				
09:00					21:00				
09:30					21:30				
10:00					22:00				
10:30					23:00				
11:00					23:00				
11:30					23:30				
12:00					00:00				

* Use the same Tuesday, Wednesday, Thursday, Friday, Saturday, and Sunday.

Schedule 6 – Form 6C: Changes Embedded Distributor Load Forecast to the Distributor

a. Submitting Distributor Name: _____

b. Receiving Distributor Name: _____

c. Name of the Interface Point: _____

(A) Changes in Typical weekly import/export+ demand profile

+ Delete where not applicable

Time	Previously Submitted		Changes		Time	Previously Submitted		Changes	
	MW	MVAR	MW	MVAR		MW	MVAR	MW	MVAR
Monday									
00:00					12:30				
00:30					13:00				
01:00					13:30				
01:30					14:00				
02:00					14:30				
02:30					15:00				
03:30					15:30				
04:00					16:00				
04:30					16:30				
05:00					17:00				
05:30					17:30				
06:00					18:00				
06:30					18:30				
07:00					19:00				
07:30					19:30				
08:00					20:00				
08:30					20:30				
09:00					21:00				
09:30					21:30				
10:00					22:00				
10:30					23:00				
11:00					23:00				
11:30					23:30				
12:00					00:00				

Schedule 6 - Form 6C (continued)

Time	Previously Submitted		Changes		Time	Previously Submitted		Changes	
	MW	MVAR	MW	MVAR		MW	MVAR	MW	MVAR
* _____									
00:00					12:30				
00:30					13:00				
01:00					13:30				
01:30					14:00				
02:00					14:30				
02:30					15:00				
03:30					15:30				
04:00					16:00				
04:30					16:30				
05:00					17:00				
05:30					17:30				
06:00					18:00				
06:30					18:30				
07:00					19:00				
07:30					19:30				
08:00					20:00				
08:30					20:30				
09:00					21:00				
09:30					21:30				
10:00					22:00				
10:30					23:00				
11:00					23:00				
11:30					23:30				
12:00					00:00				

* Use the same Tuesday, Wednesday, Thursday, Friday, Saturday, and Sunday.

**Schedule 6 – Form 6D: Distributed Generator Load Forecast Changes
(Submitted for each Generating Unit 1 MW and above)**

a. Generator Name: _____

Generator Unit Name: _____

Date: _____

(A) Changes in Forecast of typical weekly output of the unit

Time	Previously Submitted		Changes		Time	Previously Submitted		Changes	
	MW	MVAR	MW	MVAR		MW	MVAR	MW	MVAR
Monday									
00:00					12:3				
00:30					13:0				
01:00					13:3				
01:30					14:0				
02:00					14:3				
02:30					15:0				
03:30					15:3				
04:00					16:0				
04:30					16:3				
05:00					17:0				
05:30					17:3				
06:00					18:0				
06:30					18:3				
07:00					19:0				
07:30					19:3				
08:00					20:0				
08:30					20:3				
09:00					21:0				
09:30					21:3				
10:00					22:0				
10:30					23:0				
11:00					23:0				
11:30					23:3				
12:00					00:0				

Schedule 6 – Form 6D (continued)

Time	Previously Submitted		Changes		Time	Previously Submitted		Changes	
	MW	MVAR	MW	MVAR		MW	MVAR	MW	MVAR
* _____									
00:00					12:30				
00:30					13:00				
01:00					13:30				
01:30					14:00				
02:00					14:30				
02:30					15:00				
03:30					15:30				
04:00					16:00				
04:30					16:30				
05:00					17:00				
05:30					17:30				
06:00					18:00				
06:30					18:30				
07:00					19:00				
07:30					19:30				
08:00					20:00				
08:30					20:30				
09:00					21:00				
09:30					21:30				
10:00					22:00				
10:30					23:00				
11:00					23:00				
11:30					23:30				
12:00					00:00				

* Use the same Tuesday, Wednesday, Thursday, Friday, Saturday, and Sunday.

Schedule 6 – Form 6D (continued)

**(B) Changes in scheduled monthly generation output
(Submitted for each Generating Plant of 1 MW and above)**

Current Year: _____ Current Month: _____

Forecast of generation maximum output values submitted previously submitted in Form 5C for the following months of the current year.

MW: _____

MVAR: _____

MWh: _____

Changes for more than 1 MW as compared to previously submitted in Form 5C for the following months of the current year

Month	MW	MVAR	MWh	Remarks/Dates of changes

Metering Code

9.1 Introduction

9.1.1 The **Distribution Metering Code (DMC)** sets out the technical requirements for the metering of **Active Power**, **Reactive Power** and **Active Energy** and **Reactive Energy** for the purposes of **Revenue Metering**.

9.1.2 Nothing in this **DMC** precludes the application of evolving technologies and processes as they become available, provided that such applications are not inconsistent with the requirements of this **DMC** and meet the metering accuracy requirements of this **DMC**.

9.2 Objectives

9.2.1 The objective of the **DMC** is to establish technical requirements relating to **Revenue Metering** to enable the **Distributor** and the **Users** to comply with the **Electricity Supply Laws** and **Licence** obligations and that these technical requirements are consistent for all **Users**.

9.2.2 The objectives the **DMC** is to specify the following:

- (a) the technical requirements for the **Equipment** used for measurement and recording of electrical quantities required for **Revenue Metering**.
- (b) the parameters to be measured and accuracy requirements.
- (c) the technical requirements relating to installation, testing, operation and maintenance metering installations.

9.2.3 This **DMC** covers the technical requirements for **Revenue Metering** and does not address the requirements for meter reading, data collection, data adjustment and other functions associated with the calculation of bills for the supply of electricity.

9.3 Scope

9.3.1 The **DMC** applies to **Distributors**, **Consumers**, **Embedded Distributors** and **Distributed Generators** in respect of **Revenue Metering** for the following commercial transactions:

- (a) Electricity imports from **Distributed Generators**
- (b) Bulk electricity supplies to **Embedded Distributors**.

- (c) Transfers of electricity between **Distributors**.
- (d) Retail supply of electricity from **Distributors** and **Embedded Distributors** to **Consumers**.

9.3.2 **Revenue Metering** of the import of electricity from **Distributed Generators** to the **Distribution System** as part of a contract with the **Distributor**

9.4 **General Requirements**

9.4.1 **Legal Requirements**

9.4.1.1 Section 52 of the **Enactment** requires that where a **Consumer** is to be charged for electricity by reference to the quantity supplied then the quantity to be measured shall be measured by an appropriate meter. **Revenue Metering** shall therefore be installed to measure **Active Energy**, **Reactive Energy**, **Active Power** and **Reactive Power** as appropriate at all metered **Connection Points** and shall include both **Import** and **Export** metering where the measurement of bi-directional electricity flows are required to be measured by the terms of supply of electricity.

9.4.1.2 For the purposes of this **DMC** an appropriate meter is a meter that meets the technical and accuracy requirements specified in this **DMC**.

9.4.1.3 It is also a requirement of the **Enactment** that **Revenue Metering** shall be provided by the **Distributor** and shall be installed on the **Consumer's** premises at a point determined by the **Distributor**, unless it is more reasonable to install the meter outside the premises.

9.4.2 **Location of Revenue Metering Equipment**

9.4.2.1 The **Revenue Metering Equipment** shall normally be installed as close as practicable to the **Connection Point** as determined by the **Distributor**.

9.4.2.2 Where convenient or economic the **Distributor** may locate the **Revenue Metering Equipment** at a point other than the **Connection Point**; in which case an adjustment shall be made to take account of the difference between the electricity supplied and electricity measured where there is a significant difference between these quantities. The **Distributor** may make this adjustment by either adjusting the calibration of the meter or by calculating the difference between the electricity supplied and the quantity metered.

9.4.2.3 The **User** may be required under the terms of the **Connection Agreement** to provide facilities for accommodating the **Revenue Metering Equipment**, in which case, the facilities shall be provided by the **User** in accordance with the specifications and technical requirements of the **Distributor**.

9.4.2.4 **Revenue Metering Equipment** shall be installed so as to conform to the environmental conditions specified by the manufacturer and the **Distributor**. The installation shall provide protection from ingress of moisture and dust and from physical damage and vibration.

9.4.3 **Access and Security of Revenue Metering Equipment.**

9.4.3.1 The **Revenue Metering Equipment** shall be installed such that the **User** has access to metering data as agreed by the distributor.

9.4.3.2 The **Revenue Metering Equipment** including any cabinet or accommodation for the **Equipment** and any associated current transformers (CTs), voltage transformers (VTs), time switches, test terminals, fuses, wiring and auxiliary supplies shall be locked and /or sealed by the **Distributor** so as to prevent unauthorised access to the **Revenue Metering Equipment** and to prevent interference with the metering **Equipment** and metered data. The keys for any locks, tools and equipment used for meter security shall only be available to **Distributors** authorised personnel.

9.4.3.3 Any passwords associated with software required for operation, maintenance and testing of **Revenue Metering** shall be secured for the use of the **Distributors** authorised personnel only.

9.4.4 **Provision of Metering Signals**

9.4.4.1 When requested by a **User**, the **Distributor** may provide facilities and access for the **User** to obtain metering data directly from the **Revenue Metering Equipment** by means of signals or otherwise, provided that such facilities do not interfere with ability of the **Revenue Metering Equipment** to perform the **Revenue Metering** function and the accuracy and security requirements specified in this **DMC** are met. The **User** shall provide the necessary communication to facilitate the access

9.4.5 Transformer Operated Metering

9.4.5.1 According to the tariff and the quantity of electricity supplied, the **Distributor** may arrange to meter the quantity of electricity supplied by measuring the parameters of current or voltage directly, known as **Whole Current Metering**, or by measuring the parameters indirectly via current transformers (CTs) and voltage transformers (VTs), known as **Transformer Operated Metering**.

9.4.5.2 **Transformer Operated Metering** shall be used to meter all supplies to **Users** connected to the **Distribution System** at **Medium Voltage** and for supplies to **Users** connected at **Low Voltage** with a **Demand** of more than 100 Amps per phase.

9.4.5.3 Where **Transformer Operated Metering** is required, the **User** may provide, or be required by the **Distributor** to provide, the metering VTs and/or CTs in accordance with the **Connection Agreement**. The VTs and/or CTs provided by the **User** shall be to the **Distributors** specification and the **User** shall provide the **Distributor** with the manufacturers test certificate. The CTs and/or VTs together with the meters shall be tested by the **Distributor** to confirm the overall accuracy of the **Transformer Operated Metering**.

9.4.5.4 Main Metering, Check Metering and additional burdens associated with **Transformer Operated Metering** shall have separately fused VT circuits. The VT primary circuit fuses to be positioned such that they can be replaced without requiring a shutdown where possible.

9.4.5.5 Test terminals shall be provided for Main and Check Meters to facilitate onsite tests. These terminals shall be in close proximity to the Meters.

9.4.5.6 The metering CTs and VTs may be used for purposes other than metering with the agreement of the Distributor. The overall accuracy requirements specified in this **DMC** shall be met and evidence of the value of the additional burden is made available and accepted by the **Distributor**.

9.4.6 Main and Check Metering

9.4.6.1 According to the tariff and the quantity of electricity supplied, the **Distributor** may arrange for the **Revenue Metering Equipment** to be duplicated either in whole or part to provide Main Metering and Check Metering.

9.4.6.2 Main Metering and Check Metering would normally be provided for **Users** connected to the **Distribution System** at **MV** with a **Demand** of more than 250,000 kWh per month or as specified by the **Distributor**.

9.4.6.3 Main Metering shall be used by the **Distributor** as the primary source of metering data for billing purposes. Check Metering shall be used by the **Distributor** for:

- (a) validation of revenue metering data;
- (b) substitution of revenue metering data; and
- (c) account estimation, to provide a means for verifying the quantity of electricity supplied in the event of the failure of the Main Metering or dispute over the quantity of electricity supplied.

9.4.7 **Summation Metering**

9.4.7.1 In all **MV** and certain **LV** installations where there is more than one circuit providing a supply of electricity at a single **Connection Point**, the **Distributor** must provide **Revenue Metering Equipment** with facilities for summation of the metering data on each circuit in order to provide a single measurement of electricity supplied at the **Connection Point**.

9.5 **Specification and Accuracy of Revenue Metering**

9.5.1 **General**

9.5.1.1 This section defines the technical and accuracy requirements for **Revenue Metering Equipment** required for the measurement and recording of electricity supply at **Connection Points**. The provisions of this section of the **DMC** shall apply equally to Main Metering and Check Metering, where provided, and to the following non-exhaustive list of **Revenue Metering Equipment**.

- (i) Active Power Meters
- (ii) Reactive Power Meters
- (iii) Active Energy Meters
- (iv) Reactive Energy Meters
- (v) Metering Current Transformers
- (vi) Metering Voltage Transformers
- (vii) Summation Metering Equipment
- (viii) Time Switches
- (ix) Test Terminal Blocks

- (x) Associated wiring fuses and auxiliary power supplies
- (xi) Data Loggers and handheld meter reading equipment
- (xii) Communication equipment such as modems
- (xiii) Antenna for transformer operated metering
- (xiv) Communication Signal Booster

9.5.2 Revenue Metering Equipment Specifications

9.5.2.1 The **Revenue Metering Equipment** shall be in accordance with and conform to relevant technical specifications and standards which shall include:

- (a) relevant Malaysian National Standards (MS);
- (b) relevant International, European technical standards, such as **IEC**, ISO and EN; and
- (c) other relevant national standards such as BS, DIN and ASA.
- (d) Relevant Guidelines for electricity meters govern by **Commission**.

9.5.2.2 All new **Revenue Metering Equipment** shall comply with the relevant **IEC** Standards.

9.5.2.3 Existing **Revenue Equipment** manufactured and tested to earlier specifications comply with this **DMC** provided that they were manufactured and tested to the equivalent specifications at the time of manufacture and meet the accuracy requirements of this **DMC**.

9.5.3 Type and Accuracy of Revenue Metering Equipment

9.5.3.1 General

9.5.3.1.1 **Revenue Metering Equipment** shall meet the accuracy requirements specified in this section of the **DMC**.

9.5.3.2 Single Phase Whole Current Metering

9.5.3.2.1 Single phase whole current metering shall be either electromechanical or electronic with current ratings up to 100 Amps.

9.5.3.2.2 Meter accuracy shall be class 2.0 for KWh meters.

9.5.3.3 **Three Phase Whole Current Metering**

9.5.3.3.1 Three phase whole current metering shall be either electromechanical or electronic with current ratings up to 100 Amps per phase.

9.5.3.3.2 Meter accuracy shall be class 2.0 for KWh meters and class 3.0 for kVArh meters.

9.5.3.4 **Three Phase Transformer Operated Metering**

(1) Active Energy (kWh) meters:

	Voltage Level 400 V & Maximum Demand less than 1000 kVA		Voltage Level 11 kV up to 33 kV & Maximum Demand	
			Up to 5MVA a month	more than 5 MVA a month
METER				
Class	2 (or higher accuracy class)		0.5 (or higher accuracy class)	0.2 (or higher accuracy class)
Accuracy	± 2%		± 0.5%	± 0.2%
Allowed Error	± 4%		± 1%	± 0.4%
CT	150/5A - 400/5A	500/5A and above		
Class	0.5	0.2	0.2	0.2
Accuracy	± 0.5%	± 0.2%	± 0.2%	± 0.2%
Burden	7.5VA	7.5VA	15VA	15VA (Indoor) 30VA (Outdoor)
VT				
Class			0.5	0.5
Accuracy			± 0.5%	± 0.5%
Burden			50VA	50VA

(2) Reactive Energy (kVAr) Meters.

	Voltage Level 400 V & M Demand upto 1000 kVA	Voltage Level 11 kV & above & Maximum Demand more than 1000 kVA
METER		
Class	3	2
Accuracy	± 3%	± 2%
Allowed Error	± 6%	± 4%

(3) Metering Transformer Accuracy

- (i) **Low Voltage** Current Transformer Accuracy shall be + or –0.5% for 150/5A to 400/5A and + or – 0.2% for 500/5A above.
- (ii) **Medium Voltage** Current Transformer Accuracy shall be + or – 0.2%
- (iii) **Medium Voltage** Transformer Accuracy shall be + or -0.5%.

9.6 Testing Requirements**9.6.1 Test and Certification Procedures**

- 9.6.1.1 Each **Distributor** shall prepare procedures for test, calibration and certification of **Revenue Metering Equipment** before being installed on the **Distribution System**.
- 9.6.1.2 The procedures for testing shall be in accordance with **Electricity Supply Laws**, other requirements under the Laws of Malaysia and the requirements of the **Commission**.
- 9.6.1.3 The procedures shall include the following non exhaustive list of features:
 - (a) The test calibration and certification process shall be overseen by the Dept. of Standards Malaysia under ISO/IEC 17025 accreditation scheme.
 - (b) All **Revenue Metering Equipment** shall be sealed by the **Distributor's** seals and accredited sticker wherever applicable to indicate that the **Revenue Metering Equipment** has been tested,

calibrated and its accuracy certified to comply the requirements of this **DMC** and legal requirements and in accordance with the certification process adopted by the **Distributor**.

- (c) All instruments used for testing and calibration of **Revenue Metering Equipment** shall be calibrated regularly by a recognized accredited testing and certification laboratory, according to the ISO/IEC 17025 requirements.
- (d) The **Distributor** shall maintain records relating to the calibration of all **Revenue Metering Equipment** including the dates and results of any tests and any other details as may be reasonably required by the **Commission**. Any such records shall be complete and accurate and retained for the life of the relevant item of **Revenue Metering Equipment**.

9.6.2 On-site Testing of Revenue Metering Equipment

- 9.6.2.1 Any **User** may request a test to be carried out to check the accuracy of **Revenue Metering Equipment** and the charges of such testing, shall be set out in the **Distributors** charging statement prepared under the **Licence**.
- 9.6.2.2 On-site tests shall be organised such that all relevant **Users** are aware of the tests and **Users** are invited to witness them if required and the test results made available to the **User** involved.
- 9.6.2.3 The **Distributor** shall ensure that when carrying out tests any interruption to measurement is avoided or minimized and arrangements made to provide substituted or estimated metering data where necessary.
- 9.6.2.4 Where a test indicates that an error is outside the specified limits of error then the error shall be recorded and the **Revenue Metering Equipment** replaced with **Revenue Metering Equipment** operating within the specified limits of accuracy as soon as is reasonably practicable.
- 9.6.2.5 Meters shall be tested if a divergence occurs between the Main Metering and Check Metering that is more than 2 times the prescribed limit of error.

9.6.2.6 Requirements for coordinating the maintenance of **Revenue Metering Equipment** between the **Distributor** and **User** to safeguard electricity supply is set out provision 6.10.4 of the **DOC**.

9.6.2.7 Relevant Guidelines for electricity meters govern by **Commission**.

9.7 Confidentiality

9.7.1 Metering data and the passwords are confidential data and shall be treated as confidential information in accordance with this **DMC** by all persons bound by the **Distribution Code**.

9.8 Disputes

9.8.1 Disputes concerning and in relation to this DMC shall be dealt with in accordance with the procedures set out in DGC4.14 of this Distribution Code.

Specific Requirement

10.1 Objectives

10.1.1 Objectives of this specific requirement are as follows.

- (a) To address special needs for planning, connection and operation of Rural Distribution System.
- (b) To facilitate the interconnection of DG.
- (c) To address specific needs for Islanded Grid.

10.2 Scope

10.2.1 The Conditions in this chapter applies to the Distributor and all Users.

10.3 Rural Distribution System

10.3.0 General

10.3.0.1 Rural parts which are connected to the Distribution System are served by long feeders without economic and technical feasibility for provision of contingency backup as required in DPC 5.4.2. Hence, there is a need to address specific requirement for rural distribution system.

10.3.0.2 Rural Distribution System is defined as MV system that has feeder length of more than 30 km from its original source of supply.

10.3.1 Security level

- (a) Sections of the **Rural Distribution System** supplied at **Medium**, may be restored in the time taken to repair or restore that part of the **Distribution System**, with a target restoration time of not more than 24 hours.
- (b) Sections of the **Distribution System** supplied at **Low Voltage** shall be restored following an outage within the time taken to repair or restore that part of the **Distribution System** with a target restoration time of not more than 24 hours.
- (c) In the case of **Force Majeure**, restoration may be delayed beyond 48 hours for the time taken to carry out repairs.

10.3.2 Exception

10.3.2.1 Due to difficulty in meeting the above conditions exception are given for the followings;

- (a) Islands or circuits that are supplied from the distribution system via submarine cables.
- (b) Locations with challenging access.

10.4 Distributed Generation

10.4.0 General

10.5.1.1 General requirement for distributed generation are described in DPC 5.8. However due to distributed generation capacity against the lower load in the distribution system, the management of the distributed generation differs from DPC 5.8, DOC 6.8, DCC 7.8.

10.4.1 Boundary of Responsibilities

10.5.2.1 The relationship between all **Users**, **Sabah Grid Code (SGC)** and **Sabah Distribution Code (SDC)** is shown in table below. This table illustrates the boundaries of the **SGC** and the **SDC**. A **Generating Plant** with a total output of 5 MW or more, which is subject to **Central Dispatch** under the control of the **GSO**, is required to comply with the relevant provisions of the **MDC**.

10.4.2 Distributed Generation Planning and Design

This section specifies the provision for various capacities of distributed generation.

Connection Capacity (MW)	Provision
<5	Sabah Distribution Code
5-15	a) Sabah Distribution Code b) Subject to central dispatch and scheduling as in Sabah Grid Code
>15	a) Sabah Grid Code b) Subject to central dispatch and scheduling as in Sabah Grid Code

10.4.2.1 The principles for connection of Distributed Generators for different classes of generation, based on size and type, are set out below.

- (a) Any Distributed Generator with a Generating Unit or a Generating Plant or a Power Station connected at a Connection Point with a net output of less than 5 MW will be required to comply with Sabah Distribution Code. This class and size of generation is not subjected to Central Dispatch under the GSO.
- (b) Any Distributed Generator with a Generating Unit or a Generating Plant or a Power Station connected at a Connection point with a net output of 5 MW to 15 MW will be required to comply with Sabah Distribution Code and the dispatch and scheduling provisions from the Sabah Grid Code. This class and size of generation is subject to Central Dispatch under the control of the GSO.

10.4.3 Power System Study

10.4.3.1 To meet the requirements specified in DPC5.4 and DPC5.8 and SRC10.5.3, the Distributed Generator with a Registered Capacity of ≥ 0.425 MW connected to the Distributor's MV Distribution System is required to conduct a detailed power system study (PSS). The objectives of the PSS are:

- (a) To identify connection scheme for the Generating plant to be connected to the Distributor's Distribution System;

- (b) To investigate the impact of the new connection to the Distribution System as well as the impact of the Distribution System to the operations of the Generating plant; and
- (c) To identify mitigation to reduce impact identified in SRC10.5.4.1 ii.

10.4.3.2 The PSS is to be conducted in accordance with the methodology and procedures agreed by the distributor. The result of PSS shall be informed to the user.

10.4.3.3 For Distributed Generators connected capacity > 5 MW, stability studies may be undertaken with the request by the Distributor. Any Distributed Generators that cause the System to become unstable under fault conditions must be rapidly disconnected to reduce the risk of Plant damage and disturbance to the Distribution System.

10.5 Formation of Islanded Grid

10.5.1 General

10.5.1.1 Some remote areas may be disconnected from the distribution system and operate independently during the disconnection period as it has adequate local generation capacity to cater for partial load. In the event of loss of grid, the islanded grid will be formed and local distribution system will operate in islanded mode

As the Islanded Grid is capable of synchronizing to the grid and isolated from the grid, the Islanded Grid shall have the capability of providing the system stability during both modes of operation. Therefore, all the generators in the Islanded Grid shall comply to DPC 5.8.

Requirements during connections to the grid shall follow the stated DPC, DOC, and DCC.

10.5.2 Operation during islanded mode

10.5.2.1 During the operation in islanded mode, distributor, DSO and users shall comply to the following requirements

- (a) Management of island
GSO shall appoint a commander for every island to coordinate the followings requirements:

- i) Response Plan
- ii) Generation and demand balance
- iii) Switching procedure

(b) Black start

10.5.3 Requirements for Black start

10.5.3.1 Upon separation from the grid, the Islanded Grid commander shall execute the island System Restoration Plan. The plan utilises **Black Start Generating Units** to progressively restore **Demand** and then to re- synchronise and interconnect islanded grid until the **Total System** is restored and interconnected.

10.5.4 Operation Criteria of Islanded Grid

10.5.4.1 The distributed generating plants in the Islanded Grid shall comply to OPC 6.5 and shall have the capability to control voltage, frequency, active and reactive power.

10.5.5 Automatic Low Frequency Load Disconnection

10.5.5.1 The GSO may achieve demand reduction by means of under frequency load-shedding relays to disconnect Demand from the Islanded Grid in accordance with provision OC4.6 of the Sabah Grid Code.

10.5.6 Automatic Low Voltage Load Disconnection

10.5.6.1 The GSO may also achieve demand reduction by means of under voltage load-shedding relays to disconnect Demand from the Islanded Grid in accordance with provision OC4.6 of the Sabah Grid Code.

10.6 Condition to accept

10.6.0 General

10.6.0.1 The Distributor upon receiving and application for connection of supply or connection of Distributed Generator shall review and decide on the application in accordance to the distributor's requirements. The distributor shall accept the application unless if such connections result in the following situations:

- (a) If the connection will result in a breach of its duties under the Enactment, Sabah Distribution Code or Sabah Grid Code or of any regulations.
- (b) If the connection does not conform to Distributor's safety standard.
- (c) If there is insufficient generating capacity in the grid.

Annexes

Annex 1 – Distributor’s Licence Obligations

Annex 2 – Standards Referenced in the Distribution Code

Annex 3 – Rules of the Distribution Code Committee

Annex 1: Distributor's Licence Obligations

1.0 Distribution Licence Standards

This section is provided for each **Distributor** to include for information the standards which the **Distributor** is required to produce and implement with the concurrence of the **Commission** in accordance with the **Licence**:

- 1 Distribution System Security and Power Quality Standards
- 2 Distribution System Operation and Maintenance Standards
- 3 Criteria for by which the performance of the **Licencee** in maintaining distribution system security and quality may be measured.
- 4 Any other standard considered necessary.

This **Distribution Code** lists the **Licence Standards** which **SESB** as Distributor is required to follow under the terms of its **Licence** in respect of **Distribution** technical matters as follows:

Contents:

1. Licence Condition 14 – 1 – Distribution System Security and Power Quality Standards
2. Licence Condition 14 – 2 – Distribution System Operation and Maintenance Standards
3. Licence Condition 14 – 3 – Criteria for by which the performance of the **Licencee** in maintaining distribution system security and quality may be measured.
4. Any other standard considered necessary.

Annex 2: Standards Referenced in the Distribution Code

Malaysian Standard Malaysian Wiring Regulations. (Under development)

Power System Design Standards

IEC Standard 60909:

Short-circuit currents in three-phase A.C. Systems

Electromagnetic Compatibility Standards

IEC 61000 –2-1 (1990-05):

Description of the environment – Electromagnetic environment for low-frequency conducted disturbances and signaling in public power supply systems.

MS IEC Standard 61000 –2-2:

Compatibility levels for low frequency conducted disturbances and signaling in public low-voltage power supply systems.

MS IEC 61000 –2-4 (1994-02):

Compatibility levels in industrial plants for low-frequency conducted disturbances.

MS IEC 61000 –2-5 (1995-09):

Classification of electromagnetic environments.

Malaysian Standard 1760 (IEC61000-2-8):

Guide on Voltage Dips and Short Interruptions on Public Electricity Supply Systems.

MS IEC 61000-3-2:

Limits for harmonic current emissions (equipment input current ≤ 16 A per phase)

MS IEC 61000-3-3:

Limitation of voltage changes, voltage variations and flicker in public low-voltage supply systems, for equipment with rated current ≤ 16 A per phase and not subject to conditional connection

IEC Standard 61000-3-4:

Limitation of emission of harmonic currents in low-voltage power supply systems for equipment with rated current greater than 16 A.

MS IEC Standard 61000-3-5:

Limitations of voltage variations and flicker in low voltage power systems for equipment with rated current greater than 16 A.

IEC Standard 61000-3-6:

Assessment of emission limits for distorting loads in MV and HV power systems.

IEC Standard 61000-3-7:

Assessment of emission limits for fluctuating loads in MV and HV power systems.

IEC Standard 61000-3-8:

Electromagnetic compatibility (EMC) Part 3: Limits –Section 8: Signaling on low- voltage electrical installations Emission levels, frequency bands and electromagnetic disturbance levels.

MS IEC Standard 61000-3-11:

Limitation of voltage changes, voltage variations and flicker in public low-voltage supply systems – Equipment with rated current ≤ 75 A and subject to conditional connection.

MS IEC Standard 61000-3-12:

Limits for harmonic currents produced by equipment connected to public low- voltage systems with input current > 16 A and ≤ 75 A per phase.

UK Energy Networks Association Engineering Recommendation P29

Planning limits for voltage unbalance in the United Kingdom for 132kV and below.

Metering Standards

IEC Standard 60044 Instrument transformers

IEC Standard 62052

Electricity metering equipment (a.c.) - General requirements, tests and test conditions.

IEC Standard 62053

Electricity metering equipment (a.c.) - Particular requirements

Annex 3: Rules of the Distribution Code Committee

- 1 These Rules of the **Committee** reproduce Sections 1 –3 inclusive from the **General Conditions** of the **Distribution Code**. These Draft Rules may be adopted by the **Committee** subject to the approval of the **Commission**

Section 2, 3 and 4 of this Annex 3: Proposed Rules of the Distribution Code Committee are the same as section 4.5 of the Distribution Planning Code and have been repeated here for the sake of convenience and continuity.

2 **Constitution of Distribution Code Committee (DCC):**

- 2.1 The **Commission** shall establish the Distribution Code Committee, which shall be a standing committee to oversee the implementation of the Distribution Code, and carry out the functions referred to in paragraph 4.5.3.

- 2.2 The **Committee** shall not have any obligations towards **Licence Standards** adopted by each **Distributor** with the concurrence of the **Commission**, and listed in Annex 1.

3 **Terms of Reference**

- 3.1 The Distribution Code Committee shall:

- a. Review the implementation of the Distribution Code
- b. Review all suggestions for amendments to the Distribution Code which the **Commission**, or any User or Distributor may wish to submit for consideration by the Committee from time to time. Publish recommendations, for public consultation, as to amendments to the Distribution Code that the Committee or any Distributor considers necessary or desirable and the reasons for therecommendations.
- c. Provide guidance in relation to the **Distribution Code** and its implementation, performance and interpretation when asked to do so by the **Distributor**, any **User** or the **Commission**.

- d. Consider what changes are necessary to the **Distribution Code** arising out of any unforeseen circumstances referred to it by any **Distributor** under **DGC** Section 4.6.

4 **Membership**

The Committee shall consist of members representing Distributors and Users of the Distribution System and observers from interested parties in accordance with the following requirements. (Committee members may also serve on the Grid Code Committee).

Member	Sabah
SESB Distribution Division	4
Other Distributors	2
Embedded Distributors	2
Distributed Generators	2
Regional Control Centres	2
Consumer Commission	1
Grid System Operator	1
SESB Transmission Division	1
SESB Planning Division	1
Any other party as an observer or a member whom the Committee feels necessary	As necessary

All members of the Distribution Code Committee shall be approved by the **Commission**. The Committee will be chaired by a Senior Officer of the **Commission** having adequate technical background.

- 4.1 The Distribution Code Committee shall establish and comply at all times with its own rules and procedures relating to the conduct of its business, which rules and procedures shall be approved by the **Commission**.

5 Alternates

- 5.1 Each Member shall have the power to appoint any individual to be his alternate and may at his discretion remove an Alternate Member so appointed. Any appointment or removal of an Alternate Member shall be effected by notice in writing executed by the appointer and delivered to the member or tendered at a meeting of the Committee. If his appointer so requests, an Alternate Member shall be entitled to receive notice of all meetings of the Committee or of sub-committees or working groups of which his appointer is a member. He shall also be entitled to attend and vote as a Member at any such meeting at which the member appointing him is not personally present and at the meeting to exercise and discharge all the functions, powers and duties of his appointer as a member and for the purpose of the proceedings at the meeting. The provisions of these Rules shall apply as if he were a Member.
- 5.2 Every person acting as an Alternate Member shall have one vote for each member for whom he acts as alternate, in addition to his own vote if he is also a member. Execution by an Alternate Member of any resolution in writing of the **Committee** shall, unless the notice of his appointment provides to the contrary, be as effective as execution by his appointer.
- 5.3 An Alternate Member shall *ipso facto* cease to be an Alternate Member if his appointer ceases for any reason to be a member. References in these Rules to a Member shall, unless the context otherwise requires, include his duly appointed alternate.

6 Voting and Representation

- 6.1 The Chairman and each other Member shall be entitled to attend and be heard at every meeting of the **Committee**. One adviser (or such greater number as the Chairman shall permit) shall be entitled to attend any meeting of the **Committee** with each Member and shall be entitled to speak at any meeting but shall not be entitled to vote on any issue.
- 6.2 Each Member (including the Chairman) shall be entitled to cast one vote. In the Event of an equality of votes, the Chairman shall have a second or casting vote.

6.3 Any person or persons entitled to appoint a Member may at any time remove that Member from office and appoint another person to be a Member in his place. A person or persons will only have the right to remove from office the Member which he or they have appointed, and will have no right to remove from office any Member appointed by another person. Whenever any individual Member or the Chairman changes, the person entitled to appoint that Member or the Chairman shall notify the Secretary in writing within seven days.

7 **Chairman**

7.1 The Chairman shall be a Senior Officer of **Commission**. The Chairman shall preside at every meeting of the **Committee** at which he is present. If the Chairman is unable to be present at a meeting, he may appoint an alternative pursuant to act as Chairman. If neither the Chairman nor any other person appointed to act as Chairman is present within half an hour after the time appointed for holding the meeting, then the meeting shall be postponed

7.2 The Chairman, or the person appointed to act as Chairman by the Chairman, shall be entitled to cast one vote. Where a Member is acting in the capacity of both Member and Chairman, he shall be entitled to cast one vote as Chairman, in addition to his one vote as Member.

8 **Secretary**

8.1 The **Chairman of the Distribution Code Committee** shall have power to appoint and dismiss a Secretary and such other staff for the **Committee** as they may deem necessary. The Secretary may, but need not be, a Member, but shall not be a Member by virtue only of being Secretary. The Secretary shall have the right to speak but, unless a Member, no right to cast a vote at any meeting.

8.2 The Secretary's duties shall be to attend to the day-to-day operation of the **Committee** and, in particular, to:

- (a) attend to the requisition of meetings and to serve all requisite notices;
- (b) maintain a register of names and addresses of Members and alternates as appointed from time to time; and
- (c) keep minutes of all meetings

9 **Meetings**

9.1 The **Committee** shall hold meetings at such regular scheduled times as it may decide. The venue for meetings shall be determined by the Members from time to time.

9.2 The Chairman or any other Member may request the Secretary to requisition further meetings by giving 21 days' notice to the Secretary. The notice shall be in writing and contain a summary of the business which is proposed to be conducted. The Secretary shall proceed to convene a meeting of the **Committee** within 7 days of the date of expiry of such notice in accordance with section 9 of these Rules.

9.3 A meeting of the **Committee** may consist of a conference between Members who are not all in one place but who are able (directly or by telephonic communication) to speak to each of the others and to be heard by each of the others simultaneously. The word "meeting" shall be construed accordingly.

10 **Notice of Meetings**

10.1 All meetings shall be convened by the Secretary with at least 14 days written notice (exclusive of the day on which it is served and of the day for which it is given), or by shorter notice if so, agreed in writing by all Members. If at any time a person has not been appointed as Secretary, or the Secretary is for any reason unable to act, the Chairman shall attend to the requisition of meetings.

10.2 The notice of each meeting shall contain the time, date and venue of the meetings, an agenda and a summary of the business to be conducted and shall be given to all Members.

10.3 By notice to the Secretary, any Member may request additional matters to be considered at the meeting and provided that such notice is given at least 10 days (exclusive of the day on which it is served and of the day for which it is given) before the date of the meeting, those matters will be included in a revised agenda for the meeting. The Secretary shall circulate the revised agenda to each Member as soon as practicable.

11 **Proceedings at Meetings**

- 11.1 Subject to clauses 8 and 9, the **Committee** may meet for the transaction of business, and adjourn and otherwise regulate its meetings, as it thinks fit.
- 11.2 Five Members present in person or by their alternates constitute a quorum.
- 11.3 If, within half an hour from the time appointed for holding any meeting of the **Committee**, a quorum is not present, the meeting shall be adjourned to the same day in the next week at the same time and place and if at the adjourned meeting a quorum is not present within half an hour from the time appointed for holding the meeting, the meeting shall be dissolved.
- 11.4 Only matters identified in the agenda referred to in clause 10.2 (or a revised agenda submitted pursuant to sub-clause 10.3) shall be resolved upon at a meeting.
- 11.5 All acts done by any meeting of the **Committee** or of a sub-committee or working group shall, notwithstanding that it be afterwards discovered that there was some defect in the appointment of a Member, be as valid as if such person had been duly appointed.
- 11.6 A resolution put to the vote of a meeting shall be decided by a show of hands.

12 **Resolutions**

- 12.1 A resolution of the **Committee** shall be passed by a simple majority of votes cast.
- 12.2 A resolution in writing signed by all Members shall be as valid and effective as if it had been passed at a meeting of the **Committee** duly convened and held and may consist of several documents in like form each signed by or on behalf of one or more Members.

13 **Minutes**

- 13.1 The Secretary shall circulate copies of the minutes of each meeting of the **Committee** to each Member as soon as practicable (and in any event within 10 Business Days) after the relevant meeting has been held.

13.2 Each Member shall notify the Secretary of his approval or disapproval of the minutes of each meeting within 15 Business Days of receipt of the minutes. A Member who fails to do so will be deemed to have approved the minutes. The approval or disapproval of the minutes aforesaid will not affect the validity of decisions taken by the Panel at the meeting to which the minutes relate.

13.3 If the Secretary receives any comments on the minutes, he shall circulate revised minutes as soon as practicable following the expiry of the period referred to in clause 12.2 incorporating those comments which are of a typographical nature and indicating, where necessary, that Members disagree with certain aspects of the minutes. The Secretary shall then incorporate those aspects of the minutes upon which there is disagreement, into the agenda for the next following meeting of the Panel, as the first item for resolution.

14 **Guidance of the Committee**

14.1 The **Committee** may at any time, and from time to time, issue guidance in relation to the **Distribution Code** and its implementation, performance and interpretation, and it may establish sub-committees and working groups to carry out such work.

15 **Sub Committees and Working Groups**

15.1 The **Committee** may establish such sub-committees from time to time consisting of such persons as it considers desirable. Each sub-committee shall be subject to such written terms of reference and shall be subject to such procedures as the **Committee** may determine. The meetings of sub-committees shall so far as possible be arranged so that the minutes of such meetings can be presented to the Members in sufficient time for consideration before the next following meeting of the **Committee**.

15.2 The **Committee** may further establish working groups to advise it on any matter from time to time. Such working groups may consist of Members and/or others as the **Committee** may determine for the purpose.

15.3 Resolutions of sub-committees and working groups shall not have binding effect unless approved by resolution of the **Committee**.

16 Vacation of Office

- 16.1 The office of a Member shall be vacated if:
- (a) he resigns his office by notice delivered to the Secretary; or
 - (b) he becomes bankrupt or compounds with his creditors generally; or
 - (c) he becomes of unsound mind or a patient for any purpose of any statute relating to mental health; or
 - (d) he or his Alternate fails to attend more than three consecutive meetings of the **Committee** without submitting an explanation to the Chairman which is reasonably acceptable to the Chairman.

17 Member's Responsibilities and Protection

- 17.1 In the exercise of its powers and the performance of its duties and responsibilities, the **Committee** shall have due regard for the need to promote the attainment of the principal objects of the **Committee** set out in clause 3.
- 17.2 In the exercise of his powers and the performance of his duties and responsibilities as a Member, a Member shall represent the interests of that person or persons by whom he is for the time being appointed pursuant to clause 4, provided that such obligations of representation shall at all times be subordinate to the obligations of the Member as a Member of the **Committee** set out in clause 16.1.
- 17.3 Protections:
- (a) The **Committee**, each Member and the Secretary shall be entitled to rely upon any communication or document reasonably believed by it or him to be genuine and correct and to have been communicated or signed by the person by whom it purports to be communicated or signed.
 - (b) The **Committee**, each Member and the Secretary may in relation to any act, matter or thing contemplated by these Rules act on the opinion or advice of, or any information from, any chartered engineer, lawyer, or expert in any other field, and shall not be liable for the consequences of so acting.

18 Member's Addresses

- 18.1 Every Member shall from time to time communicate to the Secretary his address and all notices sent to such addresses shall be considered as having been duly given.

19 Consultation and Approval of Distribution Code Amendments

The consultation and approval arrangements for Distribution Code amendments shall be as follows:

- (a) When agreed by a majority resolution of the panel a proposed amendment will normally go out to public consultation. In certain cases where minor amendments have been approved unanimously, the **Committee** may decide not to go out to public consultation, subject to the agreement of the **Commission**.
- (b) Any consultation paper required will identify the reasons for the amendment and implications for **Distributors** and **Users** and the key points for consultation. The consultation paper will be published on the **Distribution Code** website and provide sufficient time for response, as determined by resolution of the **Committee**, taking account of the nature of the modification.
- (c) At the end of the consultation period and after consideration by the **Committee**, the **Committee** will issue a report to the **Commission** setting out the results of the consultation and any revisions proposed by the **Committee** to the proposed amendment. The report will be published on the **Distribution Code** website.
- (d) Following approval by the **Commission** the **Distribution Code** amendment will be published on the **Distribution Code** website as an amendment to the **Distribution Code**

20 Publicity and Information

- 20.1 The **Committee** shall maintain transparent and inclusive arrangements for developing amendments to the **Distribution Code** including the use of the **Distribution Code** website as a means of consulting with **Users** and providing information.

21 **Annual Report**

- 21.1 The **Committee** shall prepare and provide to the **Commission** an Annual Report of the activities of the **Committee** and its sub committees and working groups in the preceding year ended 31 March.

